

**Gandhian
Spherons of Humanity:
Global Security/Peace**

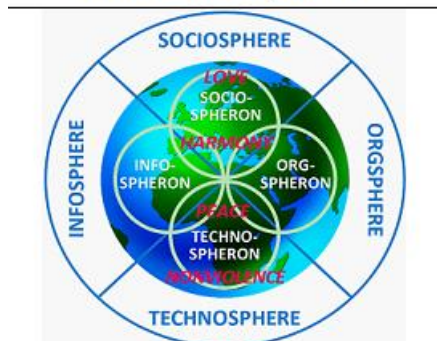

Peace/Cyberspheronics Manifesto:
The Noosphere Third Way XXI.
https://peacefromharmony.org/?cat=en_c&key=908

**Anti-Nuclear* Peace/Cyberspheronics Manifesto:
The Noosphere Third Way XXI.**

(*Anti-nuclear, only against nuclear weapons, no more)

**Solidary anti-nuclear initiative of the world civil society
Under the aegis of ICAN:
International Campaign to Abolish Nuclear Weapons.**

**Nuclear weapons: the mortal enemy of all peoples and every person,
since the Hiroshima/Nagasaki nuclear genocide 1945.**

**Earth Citizens: SOS!
Граждане Земли: SOS!**



MANIFESTO	20
МАНИФЕСТ	20

DEDICATED to the 75th anniversary of the 250 thousand civilian victims memory in the first nuclear genocidal terror of Hiroshima and Nagasaki on August 6 and 9, 1945, in order to exclude by the Global Security/Peace system of our Manifesto the very possibility of a repetition of similar crime against humanity in the future.

The Manifesto first task/step is:

Abolishing nuclear weapons in the context of global security/peace and fundamental scientific (via Cyberspheronics) support of this ICAN UN Treaty:

https://www.icanw.org/full_text_of_the_treaty



International Campaign to Abolish Nuclear Weapons (ICAN)

*"The nuclear weapons have not exculpation."
"Humanity and nuclear weapons cannot coexist."
"The nuclear weapons are genocidal terror,
absolute evil and a crime against humanity. It does
not elevate but only humiliates. This is the suicide
way."*



Beatrice Fihn, Sweden,
ICAN Executive Director,
https://peacefromharmony.org/?cat=en_c&key=943

The Manifesto Architecture:

- I. World Survival Referendum on the "*Nuclear Weapons Prohibition*" Question
- II. Key Anti-nuclear Ideas of the Manifesto Authors
- III. Manifesto Definitions. Nuclear Weapons Prohibition and its Fundamental condition
- IV. Global Security/Peace (GSP). Existential Laws
- V. Cyberspheronics. The Societal GSP Science: Theory/Thinking
- VI. Cyberspheronics Pragmatics. The Best Global Security is Global Peace

Nobel Appeal.

We, the Nobel Peace Laureates (NGOs and persons),

Call the nations, governments, UN and Security Council to stop the 75 years world's "*heading toward nuclear death*" and to ban nuclear weapons! Can our reason, will, responsibility, humanism, conscience and human moral come to reconciliation with nuclear suicide, which has been generously funded by "*a seriously ill humanity*" during 75 years? How much money and attention we devote to the Covid-19 epidemic and how stingy and indifferent to the genocidal nuclear epidemic.

We call to re-prioritize the humanitarian threat of the two epidemics and to focus of political will, science and funding on banning nuclear weapons and joint building a global security/peace system. Banning nuclear weapons will free up significant investment to fight Covid-19, economic crisis and environmental catastrophe.

Our "*Anti-Nuclear Manifesto*" is the development and substantiation of the great legacy of global security/peace and "*new thinking*" of Mahatma Gandhi, Einstein, the IPPNW founders and others, whose ideas became prisoners in the 75-year-old Babel Tower of the military-industrial complex silence/oblivion. Banning nuclear weapons will change strategic, long-term

priorities, liberate the peaceful legacy and free humanity from the genocidal weapons hostages in XXI century.

Beatrice Fihn, Executive Director of ICAN, NGO Nobel Laureate 2017,

Mairead Maguire, Nobel Laureate 1976,

John Avery, Nobel Laureate 1995,

Ernesto Kahan, Vice President of IPPNW, NGO Nobel Laureate 1985.

Preparing nuclear weapons, "***we are already living in the rubble of World War III.
Nuclear weapons are all nations shared enemy.***"

**Bernard Lown,
1985 Nobel lecture**

There is a law: who knows the unknown, the impossible is available to him. Our Manifesto knows unknown holistic spherons; therefore, the impossible is accessible to its authors: a unique paradigm of global security/peace has been created in it. If 75 years ago, the UN and its Security Council would use the knowledge of the unknown Gandhian spherons, already then the impossible would have been available to them: a global security/peace system that excludes wars and weapons, including nuclear zero. Then there would not have been the Hiroshima and Nagasaki Holocaust and the world would not have been immersed for 75 years in the hybrid phase of the third world war, in which we are now living in the closest, at a distance of only 100 seconds (Mecklin, 2020), from its hot, genocidal/suicidal phase. The history knows no return or subjunctive mood. But it leaves the future in complete control of people, depending on their knowledge, mind and will. Will we use the new knowledge of the Gandhian spherons for a new, secure/peaceful future in our common home on Earth? There is no other, scientific alternative to live in a safe/peaceful home. If in it, the UN and its SC, find at least 0.1% (\$ 1.8 billion) of the total military spending on the development of this knowledge as a general science/system of global security/peace, then the way out of the third world war ruins as created by military budgets 75 years the situation of suicide/genocide/ecocide in a common house will not be long in coming. In 2-3 years, significant contours of this self-sustaining system will be obtained. Do the UN and governments want the world peacemaking results? Or do they not need them?

GHA,

The key conclusion of solidary searching and working 15 years

The GHA 78th project.

Started: May 17, 2020.

GHA Approved on June 21, 2020.

The final version: August 4, 2020.

All previous versions of the "Anti-nuclear Manifesto" disavow.

The USA writer Robert Weir edited the English text written by Dr. Leo Semashko and coauthors.

Authors

Beatrice Fihn, Mairead Maguire, John Avery, Ernesto Kahan, Leo Semashko, Ayo Ayoola-Amale, Stephen Amoah, Ashok Chakravarthy, Pravat K. Dhal, Johan Galtung, Takis Ioannides, Olga Kashina, Michael D. Knox, Vladislav Krasnov, Norman Kurland, Bishnu Pathak, Lucas Pawlik, Maitreyee Roy, Théa Marie Robert, Bernard Scott, Rudolph Siebert, Alexander Semashko, Andrey Smirnov, Setsuko Thurlow, Robert M. Weir,

25 coauthors from 14 countries:

Austria, Denmark, France, Ghana, Greece, Israel, India, Japan, Nepal, Northern Ireland, Norway, Russia, Sweden, USA,

Support:

Mairead Maguire, Bernard Scott, Johan Galtung, Bishnu Pathak, Boris Rezhabek, Lucas Pawlik, Lana Yang, Takis Ioannides, Ernesto Kahan, Guy Crequie, Michael Ellis, Maitreyee Roy, Rudolf Siebert, Andrey Smirnov, Alexander Trubachev, Vera Popovich, Marie Robert, Pravat Dhal, Subhash Chandra, María Cristina Azcona, Adam Greenwell, Ayo Ayoola-Amale, Habyarimana Heli, Nina Novikova, Vladimir Onoprienko, Vladislav Krasnov, Andrey

Semashko, Alexander Semashko, Stephan Semashko, Susana Roberts, Delasnive Daspert, Celia Altschuler, Stephen Amoah, Olga Kashina, Robert Weir, Surendra Pathak,

The GHA 36 members from 18 countries:

Australia, Austria, Argentina, Brazil, Britain, France, Ghana, Greece, Israel, India, Nepal, New Zealand, Northern Ireland, Norway, Puerto Rico, Russia, Rwanda, USA,

Publication:

In English: https://peacefromharmony.org/?cat=en_c&key=908

In Russian: https://peacefromharmony.org/?cat=ru_c&key=819

1. World Survival Referendum on the “*Nuclear Weapons Prohibition*” Question

Three years have passed since 122 countries supported the ICAN-initiated UN Treaty on the Prohibition of Nuclear Weapons (The Treaty, 2017). As one would expect, the nine nuclear countries that generally control the world order have resolutely refused to support it with one fundamental argument: we do not have any effective guarantees of national/global security and deterrence of a potential aggressor, other than nuclear weapons. Without their unanimous collective, without exception, approval of this treaty, such a position of ignoring it can continue indefinitely until the nuclear conflict destroys humanity along with its nuclear weapons in natural but catastrophic self-denial.

There is only one remedy other than global security/peace system (see below) that can overcome the situation of endless waiting and end nuclear weapons. That vehicle could be an extraordinary “*World Survival Referendum*” (WSR) with a question (for further editing):

“Do you recognize as genocidal terror and a crime against humanity of any production, storage and use of nuclear weapons, starting with the atomic bombings of Hiroshima and Nagasaki in 1945 (250 thousand innocent civilian victims), requiring an immediate ban, only which will ensure the survival of “seriously [nuclear] ill humanity”? YES. NOT.”

This is a “referendum of survival” for the following reasons, which were defined by the “International Physicians for the Prevention of Nuclear War” (IPPNW), 35 years ago, having made an accurate, still true, objective diagnosis of nuclear weapons and humanity, which has come to terms with their coexistence.

Firstly, nuclear weapons received from them in the 1985 Nobel Lectures an assessment of the global genocidal terror, which “*holding the entire world hostage, ... continuously targeted for extinction.*” Therefore, “*we physicians protest the outrage of holding the entire world hostage [by nuclear weapons]. We protest the moral obscenity that each of us is being continuously targeted for extinction.*” (Lown, 1985).

Secondly, humanity, which has come to terms with the coexistence of the global genocidal terror of nuclear weapons, generously finances its total suicide and is unable to find an alternative, non-suicidal way to ensure global security/peace, has turned out to be a “*seriously [nuclear] ill humanity*” that is steadily “*heading toward nuclear death.*” (Chazov, 1985).

Third, the IPPNW doctors’ “*medical recipe for human survival*” is as follows: “*To save it we must arouse the conscience of the world’s peoples, cultivate hatred for nuclear weapons, repudiate egoism and chauvinism, and create favorable atmosphere of trust. In the nuclear age, we are all interdependent. The Earth is our only common home, which we cannot abandon. The new suicidal situation calls for the new thinking. We must convince those who take political decisions.*” (Ibid). “*Substantially new thinking*” (Einstein) embodies our Manifesto.

The fundamental, effective way to “*convince those who take political decisions*” is a worldwide sociological referendum of survival to ban nuclear weapons with all its generally recognized negative attributes of “*absolute evil, global terror, genocide and ecocide, weapons of a madman, suicide, burning alive, apocalyptic*” and etc. Not only doctors, but all the victims of

the atomic bombings of Hiroshima and Nagasaki, unequivocally qualify it during 75 years in this way (Fihn, 2017).

Another, complementary and developing, fundamental way of survival, prohibition and eradication of nuclear weapons lies in the solidary/partnership establishment of a scientific, cybernetic, self-regulatory system of global security/peace, to the justification of which is devoted the last two sections of our Anti-Nuclear Manifesto.

The ICAN, with almost 600 support organizations, will obviously be capable to organize a similar "**World Survival Referendum**" via the Internet in 6 UN languages in one way or another (for example, with the participation of minor children in it, for whom the parents would vote, or without them and etc.), sampling or continuous/massive sociological survey for 4-6 months.

II. The Manifesto Authors Key Antinuclear Ideas.

(Most of them are the anti-nuclear NGO's leaders)

Beatrice Fihn,

ICAN Executive Director, Sweden,
ICAN is Nobel Peace Laureate 2017,

https://peacefromharmony.org/?cat=en_c&key=943

*“At dozens of locations around the world – in missile silos buried in our earth, on submarines navigating through our oceans, and aboard planes flying high in our sky – lie **15,000 objects of humankind’s destruction**. Perhaps it is the enormity of this fact; perhaps it is the unimaginable scale of the consequences that leads many to simply accept this grim reality. To go about our daily lives with no thought to the instruments of insanity all around us. For it is insanity to allow ourselves to be ruled by these weapons.*

*Many critics of this movement suggest that ... **nuclear-armed states will never give up their weapons**. But we represent the **only** rational choice. ... Ours is the only reality that is possible. The alternative is unthinkable. The story of nuclear weapons will have an ending, and it is up to us what that ending will be. Will it be the end of nuclear weapons, or will it be the end of us? One of these things will happen. The only rational course of action is to cease living under the conditions where our mutual destruction is only one impulsive tantrum away...*

*These weapons were supposed to keep us free, but they deny us our freedoms. **It’s an affront to democracy to be ruled by these weapons** ... **We citizens are living under the umbrella of its falsehoods**. These weapons are not keeping us safe, they are contaminating our land and water, poisoning our bodies and holding hostage our right to life.”*

Fihn B. (2017) International Campaign to Abolish Nuclear Weapons (ICAN). – Nobel Lecture:

<https://www.nobelprize.org/prizes/peace/2017/ican/26041-international-campaign-to-abolish-nuclear-weapons-ican-nobel-lecture-2017/>

Setsuko Thurlow,

ICAN member, Hibakusha, Japan,

*“I speak as a member of the family of Hibakusha – those of us who, by some miraculous chance, survived the atomic bombings of Hiroshima and Nagasaki. **For more than seven decades, we have worked for the total abolition of nuclear weapons** ... We refused to sit idly in terror ... **We said: humanity and nuclear weapons cannot coexist**.*

*Today, I want you to feel in this hall the presence of all those who perished in Hiroshima and Nagasaki. I want you to feel, above and around us, a **great cloud of a quarter million souls** ...*

I was just 13 years old when the United States dropped the first atomic bomb, on my city Hiroshima. I still vividly remember that morning. At 8:15, I saw a blinding bluish-white flash from the window. I remember having the sensation of floating in the air ...

Whenever I remember Hiroshima, the first image that comes to mind is of my four-year-old nephew, Eiji – his little body transformed into an unrecognizable melted chunk of flesh. He kept begging for water in a faint voice until his death released him from agony.

*To me, he came to represent all the innocent children of the world, threatened as they are at this very moment by nuclear weapons. **Every second of every day, nuclear weapons endanger everyone we love and everything we hold dear**. We must not tolerate this insanity any longer ... we must warn the world about these apocalyptic weapons.*

*But still some refused to see Hiroshima and Nagasaki **as atrocities – as war crimes**. They accepted the propaganda that these were “good bombs” that had ended a “just war”. It was this myth that led to **the disastrous nuclear arms race** – a race that continues to this day.*

*Nine nations still threaten to incinerate entire cities, to destroy life on earth, to make our beautiful world uninhabitable for future generations. The development of nuclear weapons signifies **not a country’s elevation to***

greatness, but its descent to the darkest depths of depravity. These weapons are not a necessary evil; they are the ultimate evil...

*All responsible leaders will sign this **Treaty on the Prohibition of Nuclear Weapons**. And history will judge harshly those who reject it. No longer shall their abstract theories mask the **genocidal reality of their practices**. No longer shall "deterrence" be viewed as anything but a deterrent to disarmament. No longer shall we live under a mushroom cloud of fear...*

To every president and prime minister of every nation of the world, I beseech you: Join this treaty; forever eradicate the threat of nuclear annihilation.

When I was a 13-year-old girl, trapped in the shouldering rubble, I kept pushing. I kept moving toward the light. And I survived. Our light now is the ban treaty...

*Tonight, as we march through the streets of Oslo with torches aflame, let us follow each other **out of the dark night of nuclear terror**... This is our passion and commitment for our one precious world to survive."*

Fihn B. (2017) International Campaign to Abolish Nuclear Weapons (ICAN). – Nobel Lecture:

<https://www.nobelprize.org/prizes/peace/2017/ican/26041-international-campaign-to-abolish-nuclear-weapons-ican-nobel-lecture-2017/>

Mairead Maguire,

Nobel Peace Prize Laureate, North Ireland,

https://peacefromharmony.org/?cat=en_c&key=678

"Gandhi believed that humanity 'possessed the greatest force of non-violence, love and peace' and that it and each person are capable of using this force to change themselves and the world. In our violent world, after the atomic bombing of the Hiroshima and Nagasaki civilian population, militarism turned into murderous world state terrorism. For 75 years, its global system has taken humanity near to extinction and we have become a hostage on its nuclear scaffold of genocide and ecocide.

This anti-militarist Manifesto, based on love nonviolence harmony and peace offers an alternative to mainstream, dominant militarism. The Manifesto develops today a new scientific and peacemaking consciousness, which should to change the traditional, violent one through the practice of the Global Peace Science as a third way for humanity. It is not too late to take this path of general and complete disarmament as the scientific alternative of nonkilling and peace."

Johan Galtung, PhD,

Founder of peace and conflict studies, Norway,

Director, Transcend International,

https://peacefromharmony.org/?cat=en_c&key=599

"Militarism became world state terrorism in the United States, which launched it 75 years ago with the atomic bombings of Hiroshima and Nagasaki, retaining the right of a preventive nuclear strike. This keeps humanity in hostage of militarism, stops its humanistic evolution and threatens its survival during 75 years. Only the inevitable fall of militarism in general, and nuclear militarism first will save humanity from this threat and open the path of disarmament within global peace."

John Avery, PhD,

Nobel Peace Prize Laureate, Denmark,

https://peacefromharmony.org/?cat=en_c&key=672

*"If terror is recognized today as the most malicious inhumanity and crime against humanity, then nuclear weapons, undoubtedly, should be recognized as a potential, the highest degree of readiness in a few seconds, a global genocidal terror, unquenchable smoldering on alert at military bases, aircraft and submarines around the world. My book is devoted to this topic: **Nuclear Weapons: An Absolute Evil** (2017). The UN could have banned nuclear weapons long ago if it had been reformed according to the "UN Harmony" model created in the GHA in 2018 on the basis of cyberspheronics (global peace science) with my participation and presented in the Manifesto. Now, the proposed in it the solidary and intellectual consolidation of the world civil society under the ICAN auspices in the primary ban of nuclear weapons on a fundamental scientific basis, certainly deserves all-round support and implementation in creating an appropriate international laboratory for global security/peace. Readers may be interested in my book "A World Federation" (2018) with its chapter: "Nuclear Weapons as Collective Punishment" and others on this topic."*

Ernesto Kahan, MD,

Professor, Physician, IPPNW Vice-President in 1985, Israel,

https://peacefromharmony.org/?cat=en_c&key=338

*"As a physician and Vice President of IPPNW in 1985, when our first anti-nuclear organization was awarded the Nobel Peace Prize, I fully share the Nobel Lectures' assessment of nuclear weapons by two IPPNW leaders from the United States - Professor **Bernard Lown** and from the USSR - Professor **Yevgeny Chazov** as a*

global genocidal terror "**holding the entire world hostage**" and threatens everyone with "**continuously targeted for extinction.**" (Lown, 1985). Indeed, being held its hostage is an "outrage" over humanity and "moral obscenity" towards every person as Professor Lown qualified them in 1985. Preparing nuclear weapons, in his ingenious opinion, "**we are already living in the rubble of World War III.**"

The need to completely ban this criminal, terrorist "**weapon of genocide**" became clear to us long ago, many decades ago. But its fundamental scientific substantiation in the context of global security and peace, only in which it can be fully implemented, quickly and by all countries, without fruitless ten-year expectations, unfortunately, still does not exist.

For over 15 years, the GHA has been developing a scientific non-violent system of global security/peace, presented in its 10 books, especially in **Global Peace Science** (2016) and **Gandhica** (2019) with my participation. The proposed Peace/Cyberspheronics Manifesto, with its Third, non-violent Way of human evolution, compressed their content up to 20 pages, is a powerful contribution and support for the ICAN Treaty on the Prohibition of Nuclear Weapons. This is a worthy, fundamental and humanistic scientific initiative of the GHA, which sees the invisible - the Gandhian spherons of non-violence.

Professor Lown argued in his Nobel Lecture "**Only those who see the invisible can do the impossible.**" Therefore, the GHA offers a Manifesto for a non-violent global security/peace system, which seems impossible in a militaristic age. As a physician, I cannot stay away from this Manifesto, which deals with the preservation of the life of people and humanity as a whole. This is in line with IPPNW's updated Hippocratic Oath calling on doctors to fight nuclear weapons as the common enemy of humanity."

Norman Kurland, JD,

President, Center for Economic and Social Justice, USA, thirdway@cesj.org,
https://peacefromharmony.org/?cat=en_c&key=414

"The elimination of nuclear weapons, as well as complete/general disarmament, by and large, are impossible without a fundamentally substantiated common and holistic scientific platform/theory of the "**Global Security/Peace**" system. But this system will face very tough but fair fundamental requirements, one of which is to ensure global economic equality and economic property rights for every person. Their well-founded theory and convincing practice over several decades in the United States was presented in the works of Kelso (1958, 1968), Kurland (1982, 2014, etc.) and many of their followers. This theory allows us to answer the question: After the COVID-19 pandemic war, how can we unite to build a more just future for every world citizen?"

Louis O. Kelso, universal citizen ownership and binary economic theorist and author, inventor of Employee Stock Ownership Plans (ESOPs), and a globally-respected lawyer-investment banker, observed that money is a "yardstick," i.e., a symbolic means for measuring "economic input, economic outtake and the relative values of the real goods and services of the economic world." Equal access to money and power over the central banking system would allow every person to become economically and politically-free property-owners, without violating property rights of current owners of their current assets.

Instead of the State controlling the money system, under the proposed Capital Homestead Act, every citizen (or their parent or guardian) would have an equal opportunity to own growth voting shares in well-managed enterprises, as well as local bank members of regional and global central banks. Under the proposed the Capital Homestead Act, as each person becomes increasingly empowered to make independent family, educational, spiritual, health, social, and political choices, the State itself would become economically dependent on all citizens. This would reverse the ever-increasing and dangerous economic dependency of property-less voters throughout the world on those who control the monopoly powers of the State.

This would turn today's non-owners into economically independent owners of productive capital. Such credit would finance the purchase of new or existing productive assets needed by businesses. Future earnings on the shares would pay off the acquisition loans — in other words, using "future savings" rather than "past savings" or reductions of current consumption income to repay the capital credit. These are the key attributes of Kelso/Kurland's binary economy and economic equality

In conclusion, we should emphasize that without the perspective of similar economic equality in synergy with other holistic requirements, a ban on nuclear weapons, general/complete disarmament, global security/peace and survival, like other holistic potentials of the "**Just/Spheral Third Way**" systematically presented in our **Antinuclear Peace/Cyberspheronics Manifesto** (# 14.1.) are unlikely to be possible ".

Pravat Kumar Dhal, PhD.,

Professor and Head, Department of Education, Magadh University, Bodhgaya, India
https://peacefromharmony.org/?cat=en_c&key=890

«The fundamental scientific merit of the **Peace/Cyberspheronics Manifesto** and its unique system of global security/peace, excluding all weapons, including nuclear ones, lies in their support and development of the key Gandhian idea of societal varnas/spherons. They, according to Gandhi, define the existential law of "**non-violence as the greatest force of mankind, more powerful than the most destructive nuclear weapons.**" The GHA special book, which received the short name "**Gandhica**" (Semashko, 2019), created by the GHA 82 co-authors from 25

countries and published in four languages, is devoted to a detailed analysis and large-scale global statistical substantiation of the law of spherons nonviolence. This book contains the rationale and development of the GHA "Global Peace Science" (2016), in which the model of the global security/peace system based on spherons was first presented.

Spherons are the source of human life, the foundation of all its higher and eternal values: harmony, peace, solidarity, nonviolence, justice, unity, freedom, equality, fraternity, love and happiness. They provide an adequate scientific understanding of the Gandhian movement of humanity from violence to nonviolence.

Discovered in India, they will form the societal foundation of a new, nonviolent world order, according to Gandhi's firm conviction, which he repeated many times but the West ignored it. Therefore, we with good reason assert that without spherons, without recognition, development and key application of this fundamental idea, global security/peace will never take place, therefore, there will never be disarmament and an unconditional ban on nuclear weapons.

*The **Peace/Cyberspheronics Manifesto** is just a synopsis of "Gandhica", without a deep study of which it is impossible to fully understand this Manifesto and its system of global security/peace, excluding nuclear weapons, as well as violence/militarism in general. Without assimilating this book, the modern, scientific, peaceful and effective education of children and youth, its anti-nuclear and anti-militaristic upbringing in the spirit of Gandhian non-violence, widely practiced in India, including our university, is impossible."*

Andrey Smirnov, PhD.,

The Head of the "Novgorod Thought-Technical School O.S. Anisimov," Russia,

https://peacefromharmony.org/?cat=ru_c&key=813

"Our transitional era, overloaded with nuclear weapons and violence of all types and colors, accompanied by a crisis of the very foundations of civilization, needs a fundamentally new ideology, new thinking and new strategic projects.

*In our opinion, such a breakthrough ideology, thinking and project found their fullest expression in the **Peace/Cyberspheronics Manifesto**, which can be recognized as the first scientific strategic project to rid humanity from nuclear weapons in the context of the global security/peace system. The fundamental novelty of this project lies in the fact that not one area of human life is taken as the object of research, but the universal societal integrity of four spheres/spherons of the noosphere in unity with the biosphere and cosmos that allows building a comprehensive model, which excludes all sources and means of nuclear weapons.*

Cyberspheronics, as a metasystem approach, is most adequate to a holistic solution of the most important goal for the 21st century: the survival of humanity and the salvation of the bio- and noosphere from global nuclear ecocide/genocide. It is the way out of the civilization crisis along the Third Way (outside of capitalism/communism) to harmonize of the coexistence of different civilizations on the basis of their societally/genetically equal spheres/spherons. To solve it, this science creates a number of unique technologies. They are technologies of unified spherical statistics for all countries, technologies for creating a spherical Internet, technologies for a digital platform of a new, non-violent democracy, technologies for solving global environmental and economic problems, technologies for smartphone applications, and the like, capable of holistically control, prevent and suppress all possible sources of nuclear weapons."

Vladislav Krasnov (aka W George Krasnow), Ph.D., historian, anthropologist,

President of the Russian-American Goodwill Association, RAGA, www.raga.org, USA,

https://peacefromharmony.org/?cat=en_c&key=752

"The need for nuclear disarmament has always been recognized by the leaders of the United States and Russia, the two powers possessing 95% of their nuclear potential. At one time, the USSR responded to US atomic strikes against Japan with its own nuclear arms race. The Soviet leaders justified this with the Marxist-Leninist ideology of irreconcilability with capitalism, which supposedly inevitably degenerates into imperialism. But even during the apogee of communism in the 1980s, US President Ronald Reagan and Soviet President Mikhail Gorbachev made significant progress in curbing the nuclear arms race. Awareness of the growing risk of nuclear war forced them to abandon ideological schemes for a pragmatic goal: the survival of their own countries—and of life on Earth!

Since 1992, our peacekeeping organization of Goodwill between the United States and the new, post-communist Russia (www.RAGA.org) has been looking for every opportunity to control nuclear weapons up to their complete ban on the entire planet. That is why we joined the coalition of the Global Harmony Association (GHA). Alas, now the whole world is on the edge of the abyss.

*The "**Peace/Cyberspheronics Manifesto**" (30 pages), created in the GHA, is the Manifesto of Gandhian Non-Violence. Denying all violence, it demands the prohibition of nuclear weapons and poses a historical question: Will former ideological opponents be able to find common ground in eliminating this mutually deadly weapon? The same question I asked in my 2019 article: "**Mahatma Gandhi and Aleksandr Solzhenitsyn**..."*

If some 35 years ago the USA and the USSR had a modicum of mutual trust, today it is practically nonexistent. All past international restrictions on nuclear weapons have been dismantled, opening a new race for

*Weapons of Mass Destruction. She brought humanity as close as possible to a nuclear disaster. According to nuclear scientists (Mecklin, 2020), there are only 100 seconds left. It is time to understand the salutary role of our **Peace/Cyberspheronics Manifesto**, with its focus on global security.*

Only mutual concessions between the United States and Russia can restore trust, ensure good political will on both sides, and revive the atmosphere of cooperation that existed under Reagan and Gorbachev. Otherwise, the risk of nuclear war will grow like a snowball until it buries everyone under its avalanche. It is the will of every citizen that determines the shift towards cooperation that this Manifesto breathes. Our optimal goal: Voluntary mutual renunciation of nuclear weapons and their complete ban in all countries in the coming years.

*It needs to be stressed that our efforts toward nuclear disarmament can hardly be successful unless we also strive for social, ethnic, racial, and religious harmony and justice in each and every nation and the world. We should work in coalition and synergy with other holistic movements, such as "The Third Way" economics formulated by Louis Kelso and his successor Norman Kurland. For building a coalition we should be guided by Mahatma Gandhi's advice: "**The Satyagrahi's goal is to convert, not to coerce, the one who disagrees.**"*

Alexander Semashko,

Economist and businessman, Russia

"The Peace/Cyberspheronics Manifesto is a program for broad and long-term action, including the prohibition and prevention of nuclear weapons, hostile to each person and humanity as a whole. Therefore, by and large, every person who wants to live is vitally interested in this program. The ideas and principles of this scientific program are clearly reflected in Cyberspheronics and do not raise doubts. But from the point of view of stylistics, this program/manifesto, as a public document, should be understandable to everyone, starting with a student. Now it looks more like a scientific treatise and an appeal to the scientific world and does not cling to the soul of ordinary people. To do this, it must find another form and become a call, be a cry or an alarm, if you like - a rap that will be understandable to any young human and wake everyone up. This manifesto must find an individual dimension. It should reflect the interests of each sphere as the quintessence of every social person, aimed at love, peace, harmony, justice and equality with other people, and therefore excluding violence and weapons, especially genocidal, nuclear, intended to destroy entire nations and humanity as a whole. It is difficult and delicate, at the same time artistic, unique work that takes a lot of time, but it is necessary and inevitable. We must grow in this direction. Our path is thorny, but we will not retreat. The most important thing is that we have a foundation - a spherical approach, on the basis of which we can build any harmonious building for any purpose, including the liberation of our common home from the cancer pathology of nuclear weapons."

Robert Weir,

Author, speaker and advocate for 'peace through understanding', USA,

https://peacefromharmony.org/?cat=en_c&key=239

"The development, manufacture, and proliferation of nuclear weapons has been (along with climate change) one of the most acute and urgent problems of every nation on Earth since the United States of America dropped atom bombs on Hiroshima and Nagasaki, Japan, 75 years ago. For three-quarters of a century, nuclear weapons have been—and are—the greatest threat to humanity as well as global ecology and economy. Unless disarmed and outlawed by all nations, the potential for nuclear destruction will continue into the unforeseeable future.

However, eliminating the potential for another Hiroshima/Nagasaki nuclear holocaust requires not only speeches, journalistic editorials, or even massive protest campaigns. Elimination of warfare materiel starts with a shift in thinking by government leaders who are willing to set aside their personal profiteering agendas and, instead, adopt a paradigm of universal peace.

This paradigm of peace could then lead to the establishment of formal peace institutions by national governments and world organizations in which the top elected and appointed leaders would listen to and accept the advice of experts educated in the methods of diffusing conflict and creating harmonious international relationships ... by means of discussion, dialogue, diplomacy, and détente rather than brute military force.

In the United States in 1793, Benjamin Rush, an American physician, civic leader, humanitarian, educator, and a signer of the US Declaration of Independence, wrote an essay titled "A Plan of a Peace-Office for the United States." Rush proposed that this Peace-Office would be created as a department within the United States Cabinet, which serves as the top advisory council within the executive branch of the US federal government; it would be headed by a Secretary of Peace. Thus, the Peace-Office would be on an equal footing with the US Department of War (now called Department of Defense), which the new government had already established on August 7, 1789.

*Rush wrote that the purpose of this proposed Peace-Office would be to "**promote and preserve perpetual peace in the United States.**" Its primary responsibility would be "**to inspire a veneration for human life, and a horror at the shedding of blood.**" It would advocate that "**to subdue that passion for war ... militia laws should everywhere be repealed, and the military dresses and military titles should be laid aside.**" (Source: https://en.wikipedia.org/wiki/Department_of_Peace)*

Unfortunately, Rush's concept failed to attain passage by the United States Congress—as was also the case for measures that would have abolished slavery and granted the right to vote to women.

In the 20th century, various peace advocates in the US have attempted to legislate the establishment of a Cabinet-level Department of Peace (DoP)—most prominently in the 1920s through the 1970s and again in the early 21st century, but to no avail.

Currently, the creation of a US Department of Peace is being addressed by the Peace Alliance and the Student Peace Alliance. Both are national nonpartisan nonprofit organizations that support independent grassroots political movements. From 2006 to 2009, I was the chair of the DoP chapter in Southwest Michigan. Try as we may, we could not convince our local Congressional representative to support the legislation introduced by Rep. Kucinich.

The concept of a Department of Peace is mentioned in the Global Harmony Association's (GHA) "**Peace/Cyberspheronics Manifesto**." As a world civil society with a long-term roadmap for prohibition, control, and prevention of nuclear weapons, ICAN is in a position to be the prototypical model for respective national and international government bodies to establish a Department of Peace in the future. Creation of a Peace Department or a Peace Office within ICAN will be one way for ICAN, working with a fundamental scientific platform within the world's international societal laboratory, to achieve its goal, as proposed in our Manifesto.

As an advocate of the concept of "peace through understanding," I hope that ICAN is successful in this endeavor."

Rudolf Siebert, PhD,

Professor of Religion and Society, Department of Comparative Religion,
Western Michigan University, Michigan, USA

http://peacefromharmony.org/?cat=en_c&key=51

"The ICAN remarkable ICAN to ban nuclear weapons, supported by many countries and our "**Peace/Cyberspheronics Manifesto**" within the framework of the "**Just/Spherical Third Way**" can and should seek a religious dimension. First of all, it can be broad support of world religions and believers of all confessions, which clearly express their peacemaking and anti-nuclear orientation. I analyze this perspective in more detail in my recent article "**The Third Way**", written for our Manifesto (Siebert, 2020)."

Bishnu Pathak, PhD,

Professor, Commission of Investigation on Enforced Disappeared Persons, Nepal,

https://peacefromharmony.org/?cat=en_c&key=910

"The main merit and the greatest force of non-violence against genocidal nuclear weapons of our "**Peace/Cyberspheronics Manifesto**" lies in its "essentially new way of thinking" (Einstein) by the Gandhian spheres/spherons. Its technology, foundations, details and procedures are disclosed in the book, which is basic for the Manifesto - GHA "**Gandhica**" (2019, 240 pages). As you know, attempts to solve problems with traditional thinking are unsuccessful. This law of thought was formulated by Einstein, when he wrote 70 years ago that any fundamental problem "**cannot be solved at the same level of thinking at which we created it.**" To solve them, a "**substantially new way of thinking of humankind**" by spheres and spherons is needed, which is presented in the GHA 10 books for 15 years of its work and is condensed, on 20 pages, expressed in our Manifesto. Only spherons exclude violence, war, weapons, including nuclear deals. According to Gandhi's definition, they constitute the first law of human life. Therefore, without studying the Gandhian thinking by spherons, it will hardly be possible in ICAN to understand the proposed Manifesto in order to effectively use it to deeply address the issue of banning nuclear weapons in the context of the global security/peace system. To master new, spherical peacemaking thinking, ICAN could organize a special seminar and a school of "**Gandhian literacy**", in which the Manifesto thinking could be studied along with its basic textbooks: "**Gandhica**" (2019) and "**Global Peace Science**" (2016) and "**The ABC of Harmony**" (2012). This would be the most fundamental ICAN preparation for the achievement and implementation of a nuclear ban."

Lucas Pawlik, PhD,

Cybernetician, Ecologist and Therapist, Austria,

https://peacefromharmony.org/?cat=en_c&key=887

"Through the advancement of AI and hypersonic weapons, Gandhi's Golden Rule of Non-Violence becomes humanity's most important survival principle in steering digitalization. We either non-violently hack humanity's digitally empowered circle of violence or die from its escalation.

My contribution as cybernetician to the **Peace/Cyberspheronics Manifesto**, which will be used as an intellectual instrument for prohibiting nuclear weapons, is the brief essay of my fundamental ideas in "**The Conclusion of Gandhica**" (2019). My essay is based on a synthesis of the ideas of my teacher and friend Heinz von Foerster and Gandhi's Golden Rule of Nonviolence. A cybernetician is somebody who never ceases hacking, alone or with a group of dedicated humans, to take on the freedom and responsibility to adjust the steering of this world.

The key idea of my essay is that in the **Gandhica and the Manifesto** we have prepared a "hacking"/change of partial, militaristic, nuclear cybernetics, providing control and supersonic delivery of nuclear weapons along with the corresponding digitalization, by holistic, non-violent, humanistic cybernetics of the Gandhian spheres/spherons with appropriate digitalization based on holistic spherical statistics deployed in Gandhica. Only as a result of similar hacking/change we can expect not only a ban, but also a complete exclusion of nuclear weapons from the evolution of humankind. The Gandhian nonviolent cybernetics disclosed in our texts - cyberspheronics and the corresponding statistical digitalization, which ensure the creation of a nonviolent system of global security/peace, is the hacking/replacement of militaristic violent cybernetics and the digitalization of supersonic nuclear bombs/missiles, which have completely prepared the inevitable nuclear ecocide/genocide for humanity and the biosphere. It's only a matter of time and reason.

The absolutely humanistic goal of banning nuclear weapons requires the ICAN to be equipped with the most effective tools for their destruction from the inside and prevention from the outside, which are offered by the Gandhian cyberspheronics and its spherical digitalization in our **Manifesto**. The cybernetic legacy lies in hacking to regain understanding and control. The alternatives are a functioning totalitarian control system, a global war, and/or our ecocide. The engineers have already hacked our world. We perpetuate the war and compete to increase the production of weapons and control them, while the main task of humanity is the non-violent self-organization of its life on the basis of its societal genetic spherons, as Gandhi predicted.

Like those cyberneticians fleeing the Second World War, uniting from all over the world united, humanity needs to unite now to solve the task of digitalization: how to unite human and machine intelligence as our **Manifesto** suggests. We either imagine and act on a common non-violent solution, or soon any moment of humanity's digital transformation, even without human interference, could be our last.

My conclusion. Today we need a new BCL-like research and learning labs, as our **Manifesto** suggests, through which we can take on the responsibility to re-design our evolution, to steer our from our impending collapse into our future through and beyond traditional digitalization. It will be a non-violent Gandhian breakthrough of a qualitatively new information and social Era with "a substantially new manner of thinking" by spheres/spherons."

Olga Kashina, PhD,
Statistician and economist, Russia,

https://peacefromharmony.org/?cat=ru_c&key=757

"Peace and anti-nuclear movements are weak because they lack effective scientific instruments. For 15 years of work, the GHA was able to create several similar tools, the most effective and promising of which is fundamentally innovative spherical statistics in its most relevant part of spherical statistics of spherons. Its incomparable advantage is its holistic, universal/global scale based on the logic of thinking from the whole to its spherical parts. Traditional statistics do not know anything like this in its thinking, so it remain partial, nationally limited, torn/fragmented and devoid of integrity/wholeness. Therefore, it is far from scientific, objectivity, often acts as a tool for manipulation and is by than the third: "**truth, lies and statistics.**" Spherical statistics of spherons orders and organizes traditional statistics into a fundamentally new tool for knowledge and governance. It is substantiated by the world statistics of 76 countries represented in **Gandhica** (2019) and constitutes the irrefutable empirical foundation of the humanity spherons at all its levels from the individual, family, school to the region, country and the world as a whole. In this capacity, spherical statistics is the most effective quantitative and mathematically (mathematical statistics, matrix algebra, fractal mathematics, etc.) armed digital instrument of the "**Global Security/Peace**" system, which constitutes the main positive content of our "**Manifesto of Peace / Cyberspheronics**" and the most fundamental scientific alternative to nuclear weapons, as well as militarism in general. Therefore, ICAN cannot do in achieving its goal of banning nuclear weapons without spherical statistics in general, spherons in particular that I firmly declare on the basis of all my life and scientific experience as a professional statistician. But for the development of spherical statistics, ICAN needs to create an appropriate funded scientific institute or laboratory, organizationally and scientifically independent from the institutes of traditional statistics but using it and cooperating with it that is unfolded in our **Manifesto**."

Maitreyee Roy, PhD,
Sociologist, Cybernetician, India,

https://peacefromharmony.org/?cat=en_c&key=481

"While referring to our "**Manifesto of Peace/Cyberspheronics**", I would prefer to rely on Gandhi only. Hence I prefer to add the gist of Gandhi's reaction and his agony score, when he learnt about the discovery of the nuclear weapon, to quote his own expression in his own words.

There have been cataclysmic changes in the world. Do I still adhere to my faith in truth and nonviolence? Has not the atom exploded that faith? Not only has it not done so but it has clearly demonstrated to me that the twins constitute the mightiest force in the world. Before it, the atom bomb is of no effect. The two opposing forces are wholly different in kind the one moral and spiritual, the other physical and material. The one [truth] is infinitely superior to the other, which by its very nature has an end. The force of the spirit is very progressive and endless. Its

full expression makes it unconquerable in the world. In saying this, I know that I have said nothing new. I merely bear witness to the fact. What is more, that force resides in everybody, man woman, and child, irrespective of the colour of the skin. Only in many, it lies dormant, but it is capable of being awakened by judicious training.

It is further observed that without the recognition of this truth and due effort to realise it, there is no escape from self-destruction. The remedy lies in every individual training himself for self-expression in every walk of life, irrespective of response by the neighbours. ... You cannot successfully fight them with their own weapons. After all, you cannot go beyond the atom bomb. Unless we can have a new way of fighting imperialism of all brands in place of the outworn one of a violent rising, there is no hope for the oppressed races of the earth.”(Gandhi, 1982, 1998, 2014). “The weapon of violence, even if it is the atom bomb, becomes useless when it is matched against true non-violence.” (Gandhi, 1946)

About Gandhi not without reason say: “**Some men changed their times...One man changed the World for all times!**”

Ayo Ayoola-Amale, JD, MCI Arb, CMC, FIMC,
Jurist, Certified Conflict Resolution Consultant & Trainer, Nigeria,
https://peacefromharmony.org/?cat=en_c&key=524

«Humanity stands at the crossroads of whether to save itself, other living things and the planet from self-destruction through the insanity of nuclear weapons proliferation. The world's women and Children bear enormous burdens in times of conflicts and war. They are staunch opponents of nuclear weapons and supporters of their prohibition. Women and children, on average, make up about 70% of the population. Consequently, the scale of its demographic influence and population weight with regards to the gender/child dimension of the prohibition of nuclear weapons. Similarly, the importance of this dimension in the positive support of the “**Global Security/Peace**” system acknowledged in our “**Peace/Cyberspheronics Manifesto**”. Hence, gender is a main concern for The International Campaign to Abolish Nuclear Weapons (ICAN). And for us, as leaders of the international Women GHA (https://peacefromharmony.org/?cat=en_c&key=815).

When the two atomic bombs dropped on August, 1945 by the US forces completely destroyed Hiroshima and Nagasaki on the spot, killed and wounded hundreds of thousands of people devoid of discrimination, it not only brought total human violence to the environment but it was a volcanic eruption on souls, spirits and generations unborn. For over 70 years those who barely ‘survived’ have struggled to live on, afflicted with deep anxiety of the very likely consequences of radiation on their children and future generation. Yet, wars and conflicts are still going on globally and nuclear weapons are being used to threaten others. The damaging power of current nuclear weapons, and moves to develop new “weapons of the evil spirit” that could wipe out the entire human race, destroy the environment and all other creatures on this planet.

The importance of the ban of nuclear weapons cannot be relegated to the fringes of policy discussions. There is an urgent need to ensure that nuclear disarmament is moved to the center stage. All nations must prohibit the use, development, production and possession of biological weapons and also ban and eliminate nuclear weapons by treaties. As we all know, nuclear weapons are far more destructive than chemical weapons.

The continuing worsening of the nonproliferation regime, the uncertainty of the position of Russia and the US in this regard, the rapid rise of North Korea as a nuclear-weapon state and of Iran as a possible weapon state, concerns about another new nuclear power, Pakistan, and great concerns about disclosures concerning nuclear weapon programs in Libya, Syria, and possibly Burma have all raised.

Nuclear weapons are being used to threaten others, wars and conflicts are still going on in the world, and many lives of innocent people are lost. We can and must think more deeply about the significance of moving the money from war to peace and their relationship to social development. We can and must think about what to do to sustain our future, and planet by protecting the environment, increasing social development funding, and other needed public services that could otherwise have gone into military expenditures causing massive loss of lives and resulting in millions of dollars in military expenditure.»

Théa Marie Robert,
Choreographer and Poet, France,
https://peacefromharmony.org/?cat=en_c&key=467

“The absolute opponents of nuclear weapons and absolute supporters of their prohibition are women and minor children, who, on average, make up about 70% of the population. Therefore, the gender/child dimension of the prohibition of nuclear weapons is the main one in terms of the scale of its demographic influence and population weight. Likewise, the significance of this dimension in the positive support of the “**Global Security/Peace**” system justified in our “**Peace/Cyberspheronics Manifesto**”. Therefore, gender is a priority for ICAN. We, as leaders of the international Women GHA (https://peacefromharmony.org/?cat=en_c&key=815) and various national and regional women's organizations, are ready to provide all-round organizational and informational support to ICAN within our areas of work on the ground. We are also ready to take the most active intellectual participation in the creation, development and implementation of the special international gender/children's program of the ICAN together with its women leaders. We pay special attention to the need for minor children to participate in the **World**

Survival Referendum according to the GHA methodology/bill, which provides for the right to vote of these children, but that is performed by their parents, primarily mothers (Semashko, DeWitt, 2004). The participation in this referendum for children, to which they have no less life right (if not more) than the adult population, will make its results both most socially significant and most humanistically valuable, ensuring its victory, which will be indefinite only with an adult participation in the referendum. Women can also take the leadership in the "**Gandhian, Non-Violent Literacy**" program offered by our **Manifesto** and funded by ICAN. There are many other aspects of the gender/child dimension, for example, artistic, medical, poetic, sports and the like, which play a very important role in banning nuclear weapons and creating a global security/peace system."

Takis Ioannides,

Dr Literature, Historian, Writer, Poet, Greece,

https://peacefromharmony.org/?cat=en_c&key=138

*"Nuclear weapons are the pinnacle of total human violence, denying and destroying the entire pyramid of biological and social life that created it and which this monstrous weapon is aiming to destroy under it. Only insane suicides could create it, nurture it for 75 years, become its voluntary slave/hostage and not even think about the saving alternative of the "**Global Peace Science**" (2016), banishing away any thought of its prohibition. Therefore, the ICAN initiative is a great heroic enthusiasm in the spirit of the bright and reasonable heroes of Hellas, who defeat hordes of unreasonable evil monsters that lie in wait for a person at every step. The ghosts of the nuclear weapons development of 75 years have arisen historically create great responsibilities in humanity nowadays. A new perception of the new millennium must be built. According to Greek thought, in order to solve any problem, we must identify the source that produces it, the cause of its creation, and stop it in time. Only scientists' specialists make nuclear weapons. We must stop them somehow. Second, we must educate the kids properly in all levels of education. Our Gandhian "**Peace/Cyberspheronics Manifesto**" is a nonviolence sword of the compressed highest achievements of the human mind, cutting of the heads of the world Lernaean Hydra of the nuclear weapons and militarism/violence in general. Only in the unity of the ICAN and the GHA can one hope for the success and victory of the ban on nuclear. We shall act as a team, as we use to do all these years in GHA."*

Michael D. Knox, PhD,

Psychologist, Founder and Chair, The US Peace Memorial Foundation,

https://peacefromharmony.org/?cat=en_c&key=928

*"Our US Peace Memorial Foundation supports ICAN in prohibiting nuclear weapons and is in solidarity with the Global Harmony Association's "**Peace/Cyberspheronics Manifesto**" aimed at fundamental scientific justification of the ICAN action by creating a **Global Security/Peace** system that excludes war and weapons. These joint actions of ICAN and GHA will become a good spiritual and scientific basis for our planned "**US Peace Memorial**" in Washington, DC. It will be able to propel the United States towards a culture of peace and to motivate/inspire thoughtful and courageous Americans and US organizations that oppose US wars, primarily against genocidal nuclear weapons."*

Leo Semashko, PhD,

Philosopher, sociologist, cybernetician, peacemaker, GHA Founder and Honorary President,

The ISA RC51 Sociocybernetics Honourary Lifetime Member,

Initiator and Editor-in-Chief of the "**Peace/Cyberspheronics Manifesto**",

Blog: https://peacefromharmony.org/?cat=en_c&key=253

Email: leo.semashko@gmail.com

Skype: leo.semashko

Phone home: 7-812-597-6571

*"The extremely acute world situation with the nuclear threat, global security, ecological catastrophe and pandemic requires from scientists, especially cyberneticians, to be more radical, responsible, solidary and courageous in the development and application of our fundamental science with its unique, holistic, inexhaustible potential, which is disclosed only in general the perspective in our "**Peace/Cyberspheronics Manifesto**". The Manifesto key excellence, which is necessary, first of all, for the ICAN for the successful and most effective prohibition of genocidal nuclear weapons, is "**a substantially new manner of thinking**" (Einstein) by the spheres/spherons. The mastery of which provides the double impossible: 75 years of inaccessible nuclear zero in the global security/peace system and the holistic circular potential of Wiener's cybernetics, which remained unknown for humankind and still unused for the noosphere as a whole. It becomes known, organizing, used and working in the Manifesto paradigm only at the level of "**a substantially new manner of thinking**" and in synergy with other potentials of integrity: the Gandhi's spheres/spherons, Einstein's thinking, Maturana's autopoiesis, Vernadsky's noosphere and the Kelso/Kurland economy in a new form of cybernetics, in Cyberspheronics (CYBS) based on the genetic societal spherons of humanity, revealed in **Gandhica** and other GHA books for 15 years."*

Bernard Scott, PhD,
Cybernetician, psychologist, Britain,
International Center for Sociocybernetics Studies,
https://peacefromharmony.org/?cat=en_c&key=255

“Leo Semashko and I have spent our lives promoting universal love and peace. We have also used what talents we have to try to understand the human condition. Leo, a sociologist, has studied society. I, a psychologist, have studied how humans interact and learn. We both have used cybernetics to help us construct our understandings. We both believe that love and understanding lead to wisdom. I support Leo in his work to bring about a harmonious society. I thank him for his friendship, his love, and his wisdom.”

III. Definitions of the Anti-Nuclear Manifesto XXI. Prohibition of nuclear weapons and its fundamental condition.

1. **The ultimate goal:** achieving global peace/disarmament in 50 years.
2. **The immediate, most important goal:** the approval and implementation of the UN Treaty on the Prohibition of Nuclear Weapons (2017), initiated by ICAN, and subsequent nuclear disarmament in 10 years in the context of global disarmament, outside of which it is unattainable. This is the most pressing global problem and the most acute pathology of human life in its entire history, threatening its survival. The threat and danger of nuclear annihilation on a planetary scale, which is growing with each year of the accelerated improvement of nuclear weapons, is unparalleled, even in comparison with the Covid-19 pandemic, which is temporary and limited to a narrow scale.
3. **Cyberspheronics (CYBS):** a key intellectual/non-violent instrument of the Manifesto's goals, a non-alternative holistic science of global security/peace. Cybernetics is the best theoretical platform for the peace science, because it is the universal, holistic, free from any ideology and provides a synergy of the most diverse potentials of integrity/wholeness (see section 14.1.). Achieving and ensuring any peace goal, above all the prohibition of nuclear weapons, can and should begin only with the development of this science of global security/peace. Its development requires the international consolidation of the best scientific forces under the auspices of the most authoritative world organizations.
4. **The third, non-violent way of the noosphere, the kingdom of reason on Earth:** it is the only alternative to militarism/violence way of survival and prosperity of humanity in the XXI century, completely freeing it from the planetary threat of nuclear/militaristic self-destruction.
5. **The "Anti-Nuclear Manifesto of Peace/Cyberspheronics"** short titles: Manifesto, Anti-Nuclear Manifesto, CYBS Manifesto; Spherons/Humanity Manifesto; Equality Manifesto; Harmony Manifesto; Dream Manifesto; Bifurcation Manifesto; Democracy Manifesto; Manifesto of: Disarmament; Nonviolence; Survival; Salvation; Life; Justice; Unity; Solidarity; Love; Women; Youth; Gandhi; Spiritual Revolution; Humanism; Ecology; Consciousness; Enlightenment; Education; Breakthrough; Development; Partnerships; Prosperity; Civilizations, etc.
6. **The Manifesto set of titles expresses** the set/scale of its meanings, its pluralism, which as a whole constitutes *"the greatest force of non-violence of mankind/[spherons], which is mightier than the mightiest weapon of destruction"* (Gandhi). For the sake of practical accentuation, its name may be reduced to any of the listed attributes.
7. **The Manifesto humanistic essence is anti-nuclear, anti-militaristic and non-violent based on the synergy of intellectual holistic potentials of Gandhi, Wiener, Einstein, Maturana, Vernadsky and Kelso/Kurland.**
8. **Antinuclear Manifesto** is the *Gandhica* abris/synopsis** of 82 co-authors from 25 countries (2019, 240 p.). The *Gandhica* higher meaning: to ensure the victory of global peace in the 21st century, making it inevitable. It contains the cyber-science of global security/peace based on the Gandhian spherons of non-violence, justified by world statistics. *Gandhica* grew out of the *Global Peace Science* of 174 GHA co-authors from 34 countries (2016, 620 pages) and compressed to 20 pages in the *Anti-Nuclear Manifesto*. This is the result of 15 years of

solidarity international peacemaking and scientific work of hundreds of GHA members on this science.

9. **The fundamental condition** for the prohibition and eradication of nuclear weapons is the global security/peace system.

10. **The CYBS Manifesto is the Spherons Manifesto** and vice versa. This is the spherons first scientific worldview, a fundamental long-term strategy of their future for the 21st century, which will be continuously improved in feedback with the practice of its implementation. This is the thinking, consciousness and mind of spherons, their goals, historic mission and the Third, nonviolent, conscious Way to them.

11. **The Anti-Nuclear Manifesto** is open to new coauthors with new anti-nuclear ideas and for support of individuals and organizations. It ensures its continuous improvement and promotion.

IV. Global Security/Peace (GSP). Existential Laws

1. **The Gandhian, societal and genetic spheres/spherons of humanity/noosphere are fundamental, defining Gandhi's law for the GSP system.**

Briefly: *Gandhi's Law: "Four universal societal spheres/spherons constitute the genetic substance of humanity/noosphere, its GSP and prosperity system."*

2. **The GSP: the law of whole/part or integrity/partialness.** Not branches/partons (their groups) provide survival, security/peace of humankind, but only its equally necessary and sufficient, holistic spheres/spherons in their inevitable harmony, love, synergy, equality and non-violence. When the part dominates the whole, it leads to this whole death.

3. **The security/peace of a part is provided only by the security/peace of the whole,** but never vice versa, never by any part of it, no matter how strong and powerful it is.

4. **Einstein's Law-1.** The GSP system cannot be comprehended and designed at the same level of traditional partial thinking, on which the global militaristic system was created and developed, depriving security/peace of every country/part of humanity and therefore forcing each of them to arm and enter the arms race, including nuclear weapons.

Briefly: *Einstein's Law-1: "The inappropriateness/unacceptability of traditional thinking for solving global problems created by it."*

5. **Einstein's Law-2.** The GSP system can be realized and constructed only at the level of "a substantially new manner of thinking" by the Gandhian spheres/spherons of humanity at all its levels. This thinking is substantiated and developed in Cyberspheronics, in the GHA books and projects for 15 years.

Briefly: *Einstein's Law-2: "The need for a substantially new manner of thinking by spheres/spherons in order to solve global problems and build a GSP and prosperity system."*

6. **Wiener's Law.** The causal circular, direct/feedback connections of societal and genetic Gandhian spheres/spherons are the objective foundation of social Cybernetics, called Cyberspheronics, which excludes ideological distortions, widely uses mathematics and creates new digital technologies.

Briefly: *Wiener's Law: "The causal circular connections of societal spheres/spherons are the objective foundation of Cyberspheronics as a holistic Megascience of the humanity GSP and prosperity system in the XXI century."*

7. **Poincaré's Law.** "The internal harmony [of spheres/spherons in the noosphere] is the only true objective reality" (Poincaré, 1913) of humanity, determined by the mathematical laws of their circular connections and constituting an integral object/subject of Cyberspheronics.

8. **Law of the GSP beginning.** The creation of the GSP system beginning and any of its elements, in accordance with Einstein-2 law, can only be the international development of Cyberspheronics as a GSP science, overcoming its main cognitive obstacle - traditional partial thinking: Einstein-1 law.

9. **The Nuclear Weapons Prohibition Law** is a synergy of the laws of rejection of traditional, partial thinking (Einstein's law-1), the recognition of the Gandhian spheres/spherons

as societal reality and the transition on their basis to their "*substantially new manner of thinking*" (Einstein's law-2) and building GSP. Therefore, the prohibition of nuclear weapons is not the end of the GSP system, but only the beginning of its construction based on Cyberspheronics as a science of GSP of the humanity Gandhian spheres/spherons.

10. **The Law of conservation of nuclear weapons.** The traditional militaristic security system for 75 years has been based solely on deterrence by nuclear weapons. Therefore, the fundamental grounds for its voluntary refusal will be no until an alternative paradigm will create as the GSP scientific system based on Cyberspheronics convincing for all. This law is the main argument for Cyberspheronics/GSP priority international development in cooperation and trust, excluding confrontation.

11. **The Law of impotence/collapse of traditional pacifist organizations.** It is defined by their contradiction, ignorance, ignorance or inability to understand, take into account and apply the laws of Gandhi and Einstein in peacemaking thinking and action, which, for this reason, have always proved to be failures and powerless in the face of the constantly growing threat of militaristic self-destruction of humanity. This is especially convincingly proved by 75 years of priority nuclear weapons.

12. **Eisenhower's Law.** The Military-Industrial Complex (MIC) is the only subsystem/part of humanity/noosphere specially created for the production, storage, development and use of all types of weapons, including nuclear. Only the MIC requires and benefits from continuous wars, violence, militarism, priority budgetary and continuously increasing funding, priority development of military science, primarily for improving the most effective nuclear weapons. Therefore, only for the MIC the suppression of any alternative of global peace science, any organizational alternative of the Department of Peace, any alternative of peacebuilding and any alternative to their budgetary financing is required and beneficial. These alternatives in various forms tried to break through in different countries for more than two centuries, but they were all suppressed and strangled in the bud by all kinds of repression, primarily financial, depriving these alternatives of financial resources.

Only the MIC requires and benefits from constant global confrontation, tension, hostility, suspicion, mistrust, alienation, fragmentation, lies, deception, falsifications, threats, sanctions, destruction of cooperation and solidarity in all spheres and relations. The MIC creates a so-called "*militaristic security system*", built on balancing "*on the war brink*" and intimidation by force: "**PEACE THROUGH FORCE.**" The militaristic security system excludes any possibility of the GSP system, including the prohibition of nuclear weapons. The MIC has become that genocidal terrorist with nuclear weapons who commits "*the outrage of holding the entire world hostage [and] ... continuously targeted for extinction each of us... [so it is for] all nations shared enemy ... [and has already plunged us] in the rubble of World War III.*" (Lown, 1985).

Eisenhower's Law is particularly impressively proven by the 75 years of nuclear weapons heyday since 1945, since the Hiroshima/Nagasaki Holocaust. The MIC has become the only source of "*nuclear death of humanity*", the main threat to its survival and a danger to the life of the biosphere, noosphere and the planet as a whole that President Eisenhower first realized and expressed. This law is the most convincing historical illustration of the part/whole law in the case when the part seizes dominion over the whole and leads it to death, while its dominance persists and is not overcome by restoring the priority of the whole over the parts in their harmony.

Briefly: **Eisenhower's Law:** "*The military-industrial complex is the main source of the total threat to the survival of humanity and the main purposeful obstacle to the system of Global Security/Peace and Prosperity of all humankind, the solution of all its problems, including the prohibition of nuclear weapons.*"

Eisenhower's Law can only be overcome by the synergy of the first ten existential laws of the GSP system, four of which form its center.

**Summary of the Cyberspheronics Existential Laws
in its Conscious Thinking:**

Four key, system creating cognitive laws for solving global problems to build a sustainable, invincible GSP and prosperity system are:

1. *Einstein's Law-1: "The inappropriateness/unacceptability of traditional thinking for solving global problems created by it."*

2. *Gandhi's Law: "Four universal societal spheres/spherons constitute the genetic substance of humanity/noosphere, its GSP and prosperity system."*

3. *Einstein's Law-2: "The need for a substantially new manner of thinking by spheres/spherons in order to solve global problems and build a GSP and prosperity system."*

4. *Wiener's Law: "The causal circular connections of societal spheres/spherons are the objective foundation of Cyberspheronics as a holistic Megascience of the humanity GSP and prosperity system in the XXI century."*

It is a fundamental system of necessary and sufficient laws of thinking of the GSP and prosperity, free from violence, war and militarism, including nuclear weapons. These are conscious, i.e. the self-reflective and self-organizing laws of the scientific mind/thinking of Cyberspheronics. Only the synergy of its existential and cognitive laws can overcome, in theory and in practice, Eisenhower's law: *"The military-industrial complex is the main source of the total threat to the survival of humanity and the main purposeful obstacle to the system of Global Security/Peace and Prosperity of all humankind, the solution of all its problems, including the prohibition of nuclear weapons."*

The four laws of conscious, *"substantially new manner of thinking"* provide in synergy the overcoming/neutralization of **Eisenhower's** law, the solution of all global problems and the breakthrough of humanity into the new Era of Nonviolence predicted by Gandhi. Therefore about Gandhi not without reason say: ***"Some men changed their times...One man changed the World for all times!"***

Naturally, the Cyberspheronics laws system, which is now presented as a hypothesis, requires constant development of its theoretical and empirical substantiation in its internationally established and funded institutions.

V. Cyberspheronics. The Societal GSP Science: Theory/Thinking

Nonviolence in harmony/peace of varnas/spherons *"is the greatest [but still unknown] force [energy] at the disposal of mankind. It is mightier than the mightiest weapon of destruction. Nonviolence [of spherons] is the law of human life."*

Mahatma Gandhi

"The significant problems we face cannot be solved at the same [partial] level of thinking we were at when we created them." Therefore, *"we should require a substantially new [holistic, non-violent, asymmetric] manner of thinking [by spherons] if mankind is to survive."*

Albert Einstein

"Cybernetics ... will only attain its true stature if it recognises itself as the science that reaches out [to know] for that which is hidden [the depth of spherons]."

Gotthard Gunther

1. Features of Cybernetics and Cyberspheronics (CYBS). Each science outlines its object/subject, creates its own conceptual/terminological language of its knowledge/thinking, develops its own manner/method of explanation/understanding and offers its own forms of their description/expression and presentation to the outside world. Mathematics, astronomy, physics, chemistry, biology, sociology, history, psychology and other sciences develop their own special way of cognition in all of the above parameters/dimensions.

Cybernetics and Cyberspheronics are not exceptions from this rule, but its continuation. To understand and master these sciences, it is necessary to master their peculiarity in their parameters. Cybernetics includes in its object/subject observable and observing, controlled and

controlling systems that encompass the entire conceivable diversity of the universe in its integrity/wholeness of internal self-organization and governance. The universality/integrity of the object/subject of Cybernetics determines its special status as the most interdisciplinary and transdisciplinary science (Scott, 1996, 2004 and etc.).

Cyberspheronics (CYBS), while maintaining the status of Cybernetics, limits its subject only to social governance and only social systems, which are extremely complex in themselves and for cognition. This determines its highest dignity and, at the same time, its particular difficulty, making Cyberspheronics a unique science and the pinnacle of Cybernetics in these respects. To understand and master CYBS below, a thesis description of all its parameters is proposed, a detailed scan and justification of which are presented in *Gandhica* (2019).

2. Definitions/Language of Cyberspheronics (CYBS) Spherical Linguistics.

2.1. Definition-1. The CYBS Science. *Cyberspheronics is the third-order Sociocybernetics of spheres and spherons, or Cybernetics of societal spheres/spherons within the framework of a pluralistic tetradic philosophy of constructivism (Gandhica, 2019). Cyberspheronics is the science of governance/control (cyber) of spherons and the governance/control (cyber) by spherons in the unity of spherons as an objective/subjective thermodynamic environment, simultaneously observed/observing and governed/governing within their circular causality, consciously organizing its object/subject and consciously self-organizing as its actor according to the measure/level of their knowledge.*

2.2. Definition-2. Cyberspheronics Object/Subject. *It is the life/existence of society/humanity as the **noosphere** created by it on Earth. The noosphere is constituted by continuous production/autopoiesis of four necessary/sufficient **resources/products**: People, Information, Organizations, Things (the totality of created material goods and services): PIOT. The PIOT are produced in four corresponding spheres of social production/autopoiesis: Sociosphere, Infosphere, Orgsphere, Technosphere (the sphere of production of material goods and services) by the respective actors/clusters of people employed in these spheres and therefore called "spherons": Sociospheron, Infospheron, Orgspheron, Technospheron. Spheres/spherons differ on the PIOT products. (Gandhica, 2019).*

The spheres/spherons are inextricable duplexes of clusters of social autopoiesis/noosphere: there are no spheres of autopoiesis without its spherons as their sole actors, and vice versa; there are no spherons of autopoiesis without their spheres as their necessary infrastructures. Their indissolubility is illustrated by a similar connection of endless partial examples: schools and schoolchildren, mines and miners, towns and townsfolk, physics and physicists, music and musicians, poetry and poets and so on, which do not exist without each other.

2.3. Definition-3. Spherons of Cyberspheronics (CYBS). *Spherons are universal. They include all people from birth to death, without exception. The universality of spherons covers all human/social life/autopoiesis in its entirety, without exception, of all people, in all families, schools, enterprises, cities, regions, countries, continents and within humanity as a whole. The spherons of humanity differ only in spherical employment in the spheres of social production/autopoiesis, which is replaced by people in their life process of transition from employment in one sphere to employment in other areas. The human/people life is a permanent spherical employment and its change (Gandhica, 2019). The humanity spherons are presented in this structural model:*

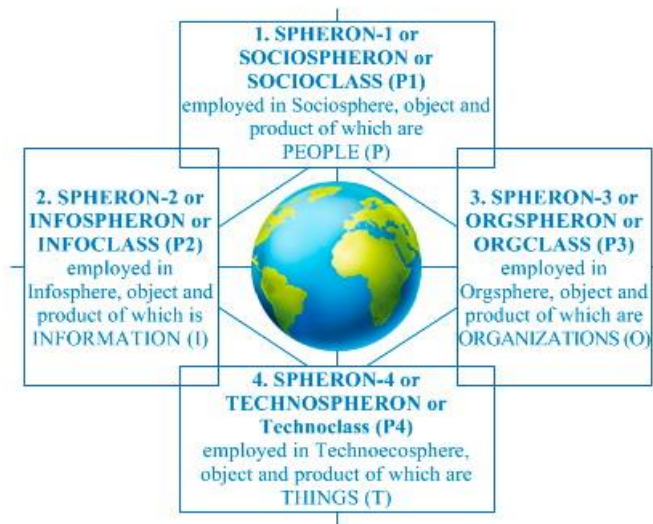

Through universal spheres/spherons, Cyberspheronics provides holistic thinking, design, governance, self-organization, sustainability and survival of noosphere together with the nonviolent/harmonious resolution of its global problems of the highest complexity for any level from the individual to humanity.

2.4. Definition-4. The CYBS Law of Universal Wholeness (LUW). (Or: The CYBS Law of Necessary Spherical Diversity.) This is the defining societal/genetic law of humanity, developing the Ashby's *Law of Requisite Variety* or necessary diversity. This law expresses a constant trend of matching the diversity of the governing system to the diversity of the governed system, which is fulfilled from two sides: from the object side and the governance subject. **The CYBS LUW determines the necessary ontological diversity of an object (society/humanity) to match with which the governing subject (governance as a whole) diversity should strive as follows.**

The autopoiesis/life of any social organism from birth to death at all levels from an individual (within the framework of his/her spherical needs, abilities and spherical employment) to humanity (in the same spherical forms) is determined by the genetic system of four necessary and sufficient spheres/spherons that ensure the reproduction of four necessary and sufficient spherical resources: People, Information, Organization, Things (material goods and services). In abbreviated form: PIOT. The processes of production, distribution, exchange and consumption of PIOT constitute together with them the corresponding spheres/spherons: Sociosphere/Sociospheron producing P; Infosphere/Infospheron producing I; Orgsphere/Orgspheron producing O; Technosphere/Technospheron producing T. In thinking of social wholeness/complexity at any level, CYBS, as a universal governing system, is limited by the diversity of these 16 spherical clusters/elements in their cognitive/attributive duplexes.

The CYBS LUW is implemented by a system of circular (direct and feedback) functional interactions of all (16) spherical clusters/elements (resources, processes, spheres and spherons) composing holistic autopoiesis/life of humanity/society. The absence of at least one spherical element in it makes its existence impossible, therefore all of them are not just necessary, but **equally** necessary and together sufficient, determining the necessary and sufficient substantial pluralism of humanity/society. In general, the diversity of autopoiesis is limited to 16 similar, fundamental/genetic spherical clusters/elements, which are determined by the four basic PIOT resources and are statistically expressed through them (below).

All the 16 spherical clusters/elements are historically embodied in the infinite variety of their cultural, national, civilizational, transitory forms from which CYBS is distracted but which constitute the subject of a whole set of branch subdisciplines. CYBS performs a fundamental ontological, cognitive and organisational trans- and interdisciplinary function in relation to them.

The CYBS LUW integrates and develops also all other laws of the first and second order Cybernetics (observable and observing systems) providing through 16 spheral societal clusters/elements the “necessary and sufficient internal diversity” of the all systems viability/autopoiesis within society/humanity.

The CYBS LUW creates the integration/synergy of fragmented disciplines of traditional Cybernetics, overcoming their fragmentation and mutual disorganization. At the highest level of synergy of Cybernetics in CYBS, it produces knowledge of genetic/societal wholeness without which no scientific/system global governance and a democratic solution to any world problem of society/humanity is possible.

2.5. Definition-5. CYBS Holistic Subject/Object in Statics. CYBS Ontology. Structural Model. *The CYBS subject/object is the planetary noosphere of the social production/autopoiesis within the biosphere (Vernadsky, 1931) and other spheres of the Earth, composed of four societal spheres/spherons. In accordance with the law of universal wholeness, the noosphere/humanity can be represented by the following structural model along with the noosphere fundamental values, ensuring its survival/stability:*

CYBS Object/Subject: Noosphere of Spheres/Spherons and its Survival Values

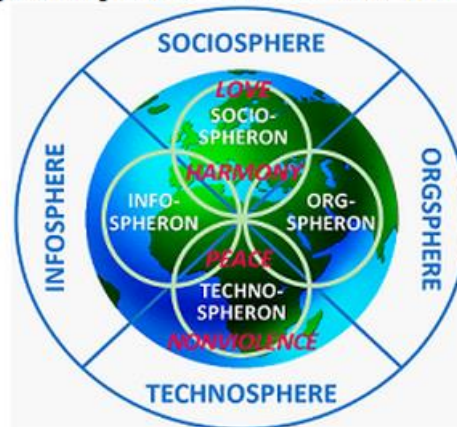

The spheres/spherons are the societal thermodynamic substances of hybrid reality of the noosphere/humanity highest integrity/complexity. The movement to the discovery, cognition and use of spheres/spherons crowns and integrates the development of Cybernetics of the first two orders. In the spheres/spherons of third-order cybernetics, it enters a new level of wholeness/complexity. In spheres/spherons optimizing holistic “*assembly of subjects/objects of development*” of society/humanity, third-order cybernetics finds self-identification and a synergistic synthesis of “*self-developing polysubjective reflective-active environments*”, ensuring “*harmony of hierarchical and network models ... in three-dimensional space*”. (Lepskiy, 2018; WOSC, 2020).

The spheres/spherons determine the genetic structure of any social “*reflective-active environments*”, transform them into specific “*spherical environments*”, overcoming their amorphousness. The spheres/spherons remove the problem of the subjectless/structureless development of the noosphere/humanity in their entire history. Spherons are the societal, genetic, higher subjectivity of humanity at all levels, at all times and in all cultures and civilizations.

2.6. Definition-6. Structural Model: Cyberspheronics Holistic Dynamics. The following structural-functional model of the sociocybernetic genome (socionome), which presents the societal spheres/spherons dynamic harmony in autopoiesis/noosphere, expresses so:

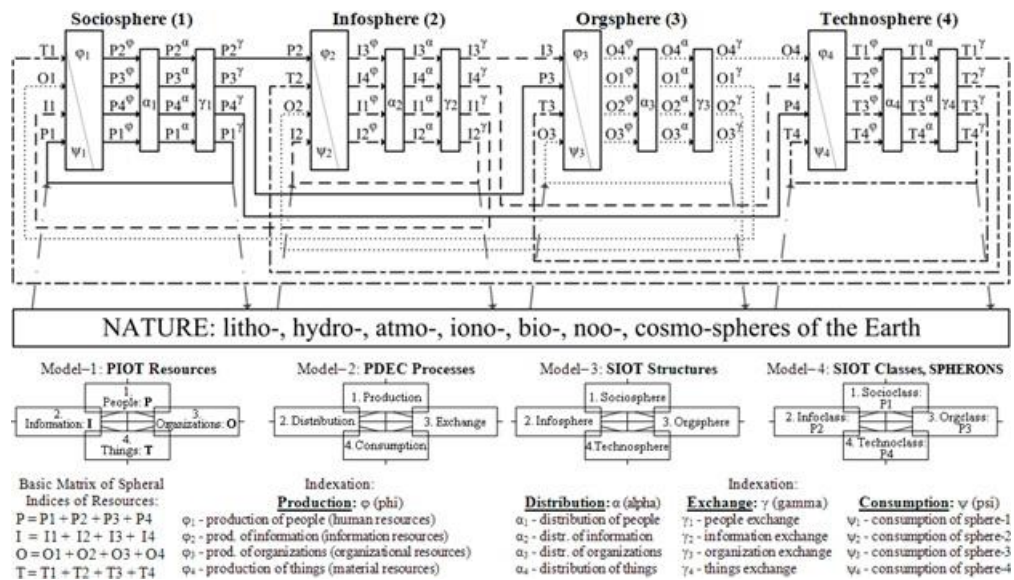

More details on SOCIONOME see: *The ABC of Harmony for World Peace*, 2012, 38–43:

https://peacefromharmony.org/?cat=en_c&key=486

<http://youtu.be/hbxY5IREOeA>

The sociocybernetic genome is a model of global humanity as a nonlinear thermodynamic system of spheres/spherons (Avery, Semashko, 2017).

2.7. Definition-7. Cyberspheronics (CYBS) Holistic Environmentalism. The noosphere/humanity environment has two levels: Earth (earthly) and Cosmos (outer space). The earth's environment is represented by its four spheres, known since ancient times: lithosphere, hydrosphere, atmosphere and biosphere, in which the noosphere or anthroposphere of humanity is its part. The terrestrial environment that determines the existence of society/humanity on the planet is called ecology, and its spheres are called ecological.

The Cosmos environment is represented, first of all, by the cosmic luminary that defines the Earth and its biosphere, the Sun, as well as the Earth's ionosphere and all its outer cosmic universe, in which Earth is only its microscopic part, the existence of which is completely determined by the cosmic whole and the laws of its evolution. If environmental spheres almost completely came under the influence (rather negative/destructive than positive/constructive) of society/humanity, then the cosmic sphere is only explored and is still far from its real influence. (Ecimovic, 2017).

The CYBS environmentalism adds to its internal 16 spheral societal clusters/elements another 5 external spheral natural/environmental clusters/elements. **They include four terrestrial, ecological spheres** (litho-, hydro-, atmo-, bio-) and one cosmic sphere integrated with the Sun. Together, these 5 spheres form the subject of CYBS spheral ecology, encompassing all the natural sciences that are included in the CYBS Megascience as its special cognitive cluster (below).

The concepts of 21 clusters/element of the CYBS object/subject as well as the concepts of their structure, interaction and evolution in social space/time, exhaust the fundamental layer of spheral linguistics in this integral science, on which the operational layer of its spheral language historically grows and modifies.

3. Duplex/Binary Method of the CYBS Tetranet Thinking. The utmost scale of the CYBS language, its integrity/complexity requires special attention to the simplicity and economy of its use. To do this, use the *Gandhica* “*Duplex/Binary Method of Linguistic Self-Organization of Tetranet Thinking*”, implemented by the pair use of the CYBS conceptual language through many duplexes of the *Gandhica* tetranet thinking categories. In duplexes of spheral linguistics, categories complement each other, outline the scale of wholeness and its extreme boundaries, or highlight its different meanings in synonymous situations, such as production/autopoiesis, etc. Categorical duplexing is an internal cognitive law of the CYBS self-organization of sphere-based

tetranet thinking. In its spheral linguistics, it is represented by many categorical duplexes, which are lexically expressed through a slash (/).

They constitute the CYBS cognitology, which is distinguished by such advantages as economy/compactness of thinking units, their quantitative/mathematical expression in terms of spheral statistics and their structural modeling in **the matrix fractals** (below). CYBS cognitology integrates the qualitative and quantitative aspects of integrity/complexity thinking, providing it with fundamental scientific knowledge and wide access to digitalization (below).

4. Spheral Statistics: the Holistic CYBS Unique Mathematical Advantage. The spheral statistics (SS) includes traditional statistics (TS) and based on it. Both of them have their own logic of cognition and a paradigm of thinking. TS embodies the simplest and most accessible trend of empirical, inductive knowledge from parts to the whole. SS realizes the most complex and least accessible vector of theoretical, deductive knowledge from the whole to its fundamental, spheral parts, constituting its integrity. TS provides the SS theoretical spheral indices with empirical content/meaning. The SS classifies, compresses, organizes, and focuses the infinite and chaotic space of empirical indices of national statistics and their meanings. SS provides the technology of an ordered system composition/decomposition (aggregation/disaggregation) of the entire chaotic set of the TS indices. The advantages/limitations and the mutual complementarity of the two statistics are disclosed in detail in *Gandhica* (2019). Here we confine ourselves only to the merits of the SS and its key instrumental, mathematical and technological role in CYBS.

If the TS main advantage is its connection with reality, with the historical context in all its details, then the SS main advantage is its penetration into the eternal fundamental and deep/genetic laws/structures of integral humanity, which ensure its life, survival, stability in its entire history from the beginning to the end. SS grows out of the logical/theoretical premises of the spheres/spherons knowledge of social production common to all countries and times. This allows the SS to become global/universal. At the same time, it cannot and does not seek to replace/supplant traditional statistics, which make up its nourishing empirical soil and source. The SS can only rely on it, contribute to its development and strengthening, and raise it to the level of fundamental science, while preserving all its necessary national characteristics. In the general methodological sense, the SS acts as a metalanguage and metalinguistics in relation to the TS object language and linguistics.

The SS emergence more than 40 years ago, its first steps and operations of composition and decomposition of indicators of two statistics are considered in a number of books (Semashko, 1992; 1999; 2002 and others, especially in *Gandhica*). Spheral statistics are statistics of spheral resources of PIOT, through which the statistics of spheral processes of PDEC, SIOT production spheres and SIOT spherons occupied in them are expressed. The spheron statistics (P) is the center of spheral statistics that defines peripheral/infrastructure spheral statistics. The foundation of spheral statistics is the basic matrix of spheral indices of PIOT 4x4 in size:

$$P1 + P2 + P3 + P4$$

$$I1 + I2 + I3 + I4$$

$$O1 + O2 + O3 + O4$$

$$T1 + T2 + T3 + T4$$

On its basis, an almost infinite system of derivatives detailed fractal matrices of another dimension is constructed according to a simple algorithm: 4×4^n , where n is a series of natural numbers in modifications from +1, or from -1, or others. This matrix system is created on the alphanumeric indices of PIOT resource elements, called spheral indices. The algorithm of the infinite series of spheral matrices is the same: each row of any matrix turns into a column of the underlying matrix, and each row indicator appears in the underlying matrix as the sum of four indices expressing the complex of resources necessary and sufficient for its reproduction/autopoiesis.

The fractal spheral matrices are described by mathematical statistics and fractal mathematics by Benoit Mandelbrot (1982), in which "a fractal is a structure consisting of parts

that are in some sense similar to the whole" expressing the ancient principle: "*all in all.*" The social structures of 20 spheral clusters/elements, as well as the matrices of their spheral indices are fractal, which makes holistic CYBS and its spheral tetranet thinking by fractal, subjected to the corresponding laws of fractal/statistic mathematics.

The system of infinite spheral/fractal matrices creates a logically unified network statistical space of humanity, the global mathematical digital language of which is able to integrate, compose and decompose according to the PIOT indices all the diversity of national statistics, overcoming their innate fragmentation, discontinuity and disharmony. Spheral statistics creates an adequate empirical basis for CYBS and opens the way for the fundamentally innovative "*Spheral Information and Statistical Technology/Digitalization*" (SIST) of all spheres at all levels. The use of CYBS together with its SIST provides effective global harmonious governance of spherons in accordance with their values and priorities at all their levels.

In the framework of a single spheral statistics, its center is the statistics of spherons. Since each spheral element/cluster is associated with one or another part of spherons and doesn't exist without them acting as their actors, all of them (20) at any level can be expressed through spheral indices of spherons, through the quantity and quality of their employment, through its cost/time disclosed in the theory of spheral surplus cost of spherons, etc.

5. CYBS as a Single Megascience of Humanity for its Spheral Third Way in the XXI Century. Spherons as observable, observing and self-governing systems are the connecting center of cybernetics of all three of its orders, making third-order cybernetics of spheres/spherons their conscious and self-organizing beginning for its previous orders. Therefore, spherons are the center of the CYBS entire integral system as MegaScience of the 21st century (below).

The CYBS spherons make cybernetics, its "*mechanisms of communication and control in [social] systems, with... circular, feedback, or self-referential processes*" (Heylighen, 2020) extremely universal/complex, maximally holistic/large-scale and global science - MegaScience, covering the whole complex of observable and observing systems (first and second order), coinciding with humanity, since the spherons exhaust and embrace it.

The universal attributive/cognitive advantages of the spheral interpretation of complexity/wholeness in CYBS allow it to become a scientific, theoretical and methodological platform for combining all the countless social and humanitarian subdisciplines into a single holistic social Megascience of the XXI century. It provides a unified scientific solution to all global problems of humanity, ensuring its survival and liberation from all systemic crises of its integrity created by traditional, partial thinking, ignoring wholeness that is cognitively inaccessible to it.

CYBS is the connecting center of Megascience of the XXI century, providing a breakthrough in the humanity scientific knowledge, consciousness and thinking to a fundamentally new, substantial level of spheres/spherons genetic reality. The CYBS spheres/spherons unite all branches and all industry groups of the population; therefore, it becomes a unified platform for all industry disciplines of human cognition. All branch (social and natural) sciences in one way or another relate to and study a person and various partial groups/communities of people, which are all parts of universal spherons, whose cybernetics is studied by CYBS. It creates a unique historical opportunity to integrate all knowledge in hundreds of its modifications into a single scientific organism Megascience of the XXI century.

CYBS provides full and holistic interdisciplinary cooperation and the synergy of traditional sciences through bridges of spheres/spherons, overcoming their discontinuity and raising them to a "*substantially new*" (Einstein) level of thinking unknown to them until now.

CYBS as Megascience will be a unique breakthrough of human knowledge in the XXI century that will free global society from all the problems that threaten its existence. But in this Megascience, the priorities of scientific knowledge are differently distributed than in the past. The cognitive priority in it is occupied by the social and human sciences, not in their traditionally stagnant and marginalized state but in the "*substantially new*" spheral state that they receive in

CYBS. Their priority in relation to the natural and technical sciences allows them to control the quality of their use/influence both on society/humanity itself and on its spherical ecology. Their priority is realized by the brilliant Socrates testament of the cognitive priority of humanity, which has not yet been realized: “*Know thyself*,” which is achieved only with the discovery of spherons and the emergence on their basis of CYBS.

Similar Megascience excludes any existence of military science (of course, not immediately but from the moment of complete disarmament) designed to destroy people. But all useful military achievements for the peaceful life of humanity, of course, are preserved and integrated in the CYBS technical sciences complex.

6. The True Level/‘Stature’ of Cybernetics: The Hidden Spheres/Spherons Science.

Fifty years ago (1972), the famous German philosopher Gotthard Gunter predicted the scientific perspective of Cybernetics: it “*will only attain its true stature if it recognises itself as the science that reaches out for that which is hidden.*” Cybernetics reached this level of true fundamental science in the CYBS, third-order Cybernetics of spheres/spherons, which (CYBS) reveals this “*hidden*”, genetic, societal, unknown to humankind “*substance*” (Einstein) of Cybernetics. This substance raises Cybernetics to the “*true stature [level/height of fundamental] science*” (Gunter) of spheres/spherons. Nothing other than the hidden, global spheres/spherons of humanity, truly/fundamentally scientific in Cybernetics does not exist. Therefore, only through them can Cybernetics in the Cyberspheronics face become the truly holistic, “*transdisciplinary and metadisciplinary*” (Scott, 2019) MegaScience of the new century.

The CYBS as the unified/holistic, interdisciplinary and transdisciplinary MegaScience reveals the true, fundamental genetic depth and hidden secret of humanity on Earth. The human/humanity has not yet known it as Socrates bequeathed, but humankind has already been opened to it by GHA’s intellectual efforts during 15 years and is presented in the first form, far from perfect, in our Spherons CYBS Manifesto.

7. Humanity Spherical Third Way (STW) of the XXI Century and its Definition in CYBS.

7.1. General characteristic. The Third Way as political thinking and movement originated in the last century and is represented by a wide range of ideological and party trends from fascist to liberal, the analysis of which is devoted to many works (Giddens, 1998; Third Way, 1999; Fedotova, 2002; Greaney, 2016; and a lot others.). The Third Way is an attempt to find more effective methods and ways of responding to the new challenges of humanity, to which the traditional ideologies of capitalism/liberalism and communism/Marxism are powerless to answer due to their obsolescence and worthlessness.

The Third Way of Cyberspheronics is the “*SPHERAL Third Way*” (STW), an alternative from its traditional variants—European, American, and Russian—which we will combine with the concept of “*Traditional Third Way*” (TTW). Comparison of TTW and STW by basic attributes/qualities, free from unnecessary details, can be presented in the following table, which expresses their 22 key differences and the STW advantages.

Attributes/Qualities	Traditional Third Way (TTW)	SPHERAL Third Way (STW)
Attitude towards holistic humanity	Partial, reduced and fragmented on branches/corporations/nations; inadequate, deadly	Integral by holistic equal spheres/spherons that are exhaustive to humanity; adequate, viable
Human/humanity rights	Do not guarantee the fundamental right: the right to life, security and the absence of war/violence	Ensures the right to life, the absence of war/violence and all others rights and freedoms
World history, its vision	Total class struggle and eternal national wars of annihilation, capture and domination. Partiality/partons history	Harmony/peace/nonviolence and partnership of equal spherons. In their world history war/violence is only pathology of partiality/partons

World Order	Unipolar, monistic, subjugating the world to economic/military leader diktat, to systemic violence of its military political blocs	Multipolar, pluralistic, subordinate to balance/harmony/nonviolence of humanity equal spherons and their partnership, hostile blocks free
Real priority	Economy, material wealth, financial capital, military-industrial complex	Social sphere, people, social capital, ecology, health, education, welfare of the population
Science/Ideology	Fragmented weak science devoid whole knowledge. Propaganda instead of science. Ideology priority. Refusal from global peace science. Concealment, closed truth. "Lie/false is God."	Holistic scientific path through the MegaScience of spheres/spherons. No propaganda, only science. Global peace science - Cyberspheronics priority. Openness of truth. "Truth is God": Gandhi
Peace education/literacy	Partial, unscientific, pacifist, sporadic, lacking in foundations of Global Peace Science (CYBS)	Holistic, free from the impotence of pacifism, universal on the fundamental basis of the Global Peace Science (CYBS)
Social equality	Impotence in the theory and practice of equality, leading to the growth of inequality constantly. Lack of scientifically recognized fundamental societal identity of equality	Scientific theory of equality in all dimensions based on the equality of spheres/spherons. Recognition of the scientific fundamental societal identity of the equality of people in spherons
Social contract of society as a whole and at each level	It is absent that is the cause of permanent group spontaneous conflicts, riots, hostility, violence and chaos. Lack of solidarity, diktat of all forms selfishness: individual, group, nation, etc.	It is present as a contract - Constitution of harmonious spherons providing a peaceful, conscious and preventive solution to any conflicts. Universal solidarity, the priority of altruism, empathy and compassion
Global peace	The complete inability to build peace that brought humanity to the nuclear eco-/geno-cide grave edge. Refusal from Peace Department	The full ability to build global peace on equality and harmony of spheres/spherons. Peace Department priority in a democracy
Non-violence	Total powerlessness in the theory and practice of non-violence: ultimate tool for conflict: violence	Full ability to ensure non-violence based on peace, equality and harmony of spheres/spherons
Disarmament	The question is not posed, arms race and militarism absolutization; nuclear disarmament is rejected	Harmonious disarmament in 50 years: transformation of national armies into a global peace/ecology corps; nuclear disarmament: the nearest 10 years
Globalization	Unfair, in the interests of international corporations	Fair, spheral, in the interests of all spherons/humanity as a whole
Democracy	Partial democracy, in the oligarchic part interests. Population participation in elections: 25-35%, in decisions - 1-5%. Systemic pathologies: inequality, militarism, corruption, nationalism, racism, decline, nature destruction	Complete, in the interests of all spherons. Population participation in elections: 75%+, in decisions - to 50%. Long-term global overcoming of all systemic traditional pathologies/challenges
The structure of political power and strategic governance	Chaotic, spontaneous, sectoral, fragmented, different at different levels, subjective, subordinate to the ruling particular elite interests; short-term governance, within 5 years, no more	Systemic, integral, spheral at all levels, conscious, objective, subordinate to the interests of spherons, society as a whole; long-term governance up to 100 years, harmonized with short-term one
Law supremacy	Partial, limited laws of the ruling elites/partons in the interests of their power, but pathological for society as a whole	Holistic, spheral laws of spherons in the interests of society as a whole, taking into account the interests of all its parts in their harmony
Democratic Constitution	Of the partial dominant elites, their inequality and violence	Of the holistic and equal spherons, their peace, harmony, nonviolence
Mathematics	Virtually absent except for particulars	Spheral mathematical statistics, universal

Digitalization (innovation)	Weak, limited, partial, technical and surface	Strong, versatile and deep in spherical statistics - digital breakthrough
Pluralism and monism; Integrity and partial	Antagonistic monism and close to it devoid of measure traditional pluralism exclude integrity/holism, produce different types of the partial and its pathologies	Spherical, structural, four-dimensional pluralism admits, defines and produce viable integrity/holism, excluding the pathology of monism and the partial
The Future	“Sunset of Humanity”, “The End of History”, “The West Collapse”, “The USA Fall”, etc.	The prosperity of humanity, the beginning of its mature history
Progress	Qualitative social stagnation amid rapid technological progress, social obesity	Qualitative social breakthrough along with prosperity in all progress vectors

7.2. The STW Spherical Attributes. TTW does not know the spherical structure of the population, its spherical employment and spherical social production, and is deprived of its science, although it sometimes uses the spherical terminology intuitively. STW, built on the fundamental science of CYBS, creates its consciousness on spheres/spherons, starting with the priority social sphere.

1. The STW Sociosphere. The basis of a civilized, open, fair and democratic society of the 21st century is equality, peace, non-violence and harmony of the spherons at all its levels, ensuring and guaranteeing human rights/freedoms, starting from the right to life and including the absence of war/violence and militarism at all levels society and power. The social priority is children and the harmonious development of the individual instead of the economy and militarism. Priority development of social infrastructure is housing, ecology, education, healthcare, sports, recreation, etc.

2. The STW Infosphere. The innovative priority of MegaScience of Cyberspheronics and its universal information technology is spherical statistics, spherical internet, spherical digitalization as a digital breakthrough, spherical artificial intelligence, spherical applications, etc.

3. The STW Orgosphere. Spherical democracy is a quota equality of elected representatives (including gender equality) of spherons for all governmental bodies at all levels; the combination of representative and participatory democracy; children's suffrage, executed by parents, to ensure social completeness and the participatory nature of democracy; and spherical decentralization of power.

4. The STW Technosphere/Economics. Spherical harmonious market, regulated by the STW priorities, is included in the priority of the sociosphere and ecology, along with the priority of average prosperity.

Capitalism and communism are alternative pathologies of the last century, as equally militaristic, disharmonious and deadly for humanity as extreme obesity and extreme exhaustion. The TTW does not constitute and is not viable. The only fundamental alternative is offered only by STW of CYBS in a holistic, non-violent, socio-economic system of human spheres/spherons. The CYBS is a holistic scientific and harmonious worldview of the spherons STW, alternative to all unscientific, antagonistic militaristic ideologies of the past.

8. The CYBS Holistic System of Values/Human Rights. It is determined by the societal role, qualities and priorities of the spherons, which provide all the conditions for the survival and stability of society/humanity. It includes the following humanistic values/rights: life, love, peace, harmony, non-violence, truth, freedom, equality, fraternity, law, complete/truth democracy and happiness. This axiological system integrates humanistic human values/rights that are verified by long historical experience and excludes the opposite, anti-humanistic values practiced by violent and totalitarian empires: death, hatred, war, disharmony, violence, lies, slavery, inequality, enmity, arbitrariness, dictatorship, misfortune and its vicious derivatives. They created systemic social pathologies that eventually, from the inside, destroyed and denied their empires, proving

their non-viability, incompatibility with the values of life-supporting spherons and unacceptability for an integral society/humanity.

The spherons axiological system is based on the priority right of human/humanity to life/peace, excluding war/militarism, as detailed in the relevant GHA Declaration (Semashko, 2017).

9. Spherons: Social Priorities Hierarchy/Network. Spherons/people have the highest priority of wholeness as only this societal resource creates/produces all of them (PIOT), including itself, i.e. all societal integrity in its entirety and complexity. Spherons fully determine the existence/autopoiesis of society/humanity, but they can only do this through other spherical resources created by them. Therefore, the absence of any of them makes the existence of benevolent society/humanity impossible, therefore they are **equally** necessary for it. Therefore, spherons are equal in power, in the possession, use and governance of all spherical and natural resources.

This is **the spherons highest law of organizational/managerial equality**, which ensures/determines the social equality of other forms and begins to consciously act in society only with its scientific knowledge in the CYBS and with its constitutional fixation at all levels of democratic power. It provides a quota equal distribution of all power equally among elected representatives of spherons.

The spherons priority determines among people the **priority of children**, the quality of which determines the quality of society as a whole, including the highest quality of attitude toward the older generation, who gave birth, raised and reared grateful children. Their priority is ensured by the “*Children's Suffrage Executed by Parents*” (Semashko, 2004).

The spherons priority determines the **full gender equality and partnership** (Eisler, 1994), the full gender balance of power as the most optimal condition for social autopoiesis in general and its governance at all levels.

All of these societal priorities determine and create all the real conditions for **the first humanistic holistic priority** of the comprehensive and harmonious development of each individual. This was proclaimed, but never achieved in the past as a result of the dominance of other priorities: inequality, violence, power, profit, etc. This is the whole hierarchy/network of the spherons social priorities.

10. The Ineradicable Vice of Traditional Governance/Authority/Democracy. *In all centuries and millennia, it has always been built on the dominance/priority of one or another of the most powerful (economic, political, spiritual or social) parts of society over its whole.* This key/structural flaw of partial control gives rise to all its other fundamental and irremovable flaws in history: inequality of all kinds, violence, militarism, corruption, selfishness of all forms and injustice. Such partial/egoistic control/power was successful, at best, only in solving partial problems, but it remained ineffective/destructive with respect to the whole and inevitably led it to death along with its dominant partial power. Global problems created by partial power/administration, including any democracy, are insoluble for TTW, which was noted by Einstein 70 years ago (below) and proved the unsuccessful historical experience of solving these problems. The most striking example of the last century is the powerlessness of democracy in regard to nuclear weapons, the race of which it generously finances; only accelerating the approach of humanity to the global genocide/ecocide, reducing the probability of its survival to a minimum, to 100 seconds (Mecklin, 2020). The traditional governance of the ruling political systems is aimed at strengthening the interests of one of its parts (class, party, elite, etc.) to the detriment and expense of the whole interests. It mistakenly defines this part as the generative principle of the whole, which deforms it and leads it to inevitable death.

11. The Cyberspheronics (CYBS) Mission: Holistic/Spherical Democracy for the Spherical Third Way. *The CYBS first social need and mission is to reorganize the democratic way of self-government in the interests of society as a whole at all levels from local to global, in order to ensure its survival/sustainability by eliminating the root vice of traditional power. This*

mission is achieved by an equal quota distribution of power of all branches and organs between the elected representatives of the four spherons in their gender balance.

Cyberspheronics is the necessary holistic scientific thinking/consciousness/knowledge of spherons, transforming them from a spontaneous, unconscious “*actor in oneself*” into a conscious, scientifically minded democratic “*actor for oneself*”, expressing by Kant terms. Therefore, spherons and Cyberspheronics are inseparable from each other in their true mutual necessity/sufficiency as a necessary, integral actor/subject and its integral consciousness/thinking. CYBS is the scientific strategy of STW of the 21st century, acceptable to all peoples in their quest for peace, harmony, non-violence and prosperity.

Cyberspheronics is not “EGO thinking/governance” of a selfish/partial nation, party or person, leading to self-destruction of humanity/noosphere, but “ECO thinking/governance” of its survival and prosperity on Earth. This is its mission.

12. The CYBS History. Cyberspheronics (CYBS) has come a long and complex evolutionary path, starting in 1992 with the first fundamental book *Spherical Approach* (Semashko), devoted to spheres/spherons (societal groups of the population engaged in the spheres of social production/autopoiesis, where they are also called the traditional term “*spherical classes*”) and their spherical statistics. Its next step was *Tetrasociology*, which received the support of RC51 Sociocybernetics (Semashko, 2002; Scott, 2002).

CYBS develops and enriches the initial fundamental ideas of the cybernetics founders: Norbert Wiener, William Ashby, Heinz Foerster, David Stuart, Gregory Bateson, Warren McCulloch, Gordon Pask, Robert Park, Stafford Beer, Umberto Maturana and many others. These ideas received a new incentive for development and special significance in the works on Sociocybernetics, concentrated in the corresponding Research Committee (PC51) of the ISA, since its establishment in 1998, as well as in international cybernetics societies, which is reflected in the historical works of Bernard Scott (1983 – 2019).

The stratum/trend of cybernetic knowledge is organically integrated into CYBS with the trend of macro-sociological generalization and development of the four-spherical structure of social production as a whole (autopoiesis according to Maturana) in theoretical sociology. It starts with the early Marx, Danilevsky, Kovalevsky, Gandhi, Sorokin, Braudel, Parsons, Toffler, Bourdieu, including Semashko’s books for 30 years, starting with *Spherical Approach* (1992) and ending with *Gandhica* (2019) and many other sociologists.

The concept of “*Third Order Sociocybernetics*” of spheres and spherons was first introduced with the participation of Bernard Scott in the GHA collective book “*The ABC of Harmony*” (2012).

13. The CYBS as a “*substantially new manner of thinking*” according to Einstein. The CYBS conception/paradigm implements the Albert Einstein great testament more than 70 years ago for the humanity survival, which has not been fulfilled so far. He wrote: “*The significant problems we face cannot be solved at the same level of thinking we were at when we created them.*” Therefore, “*we shall require a substantially new [holistic and nonviolent, asymmetric] manner of thinking if mankind is to survive.*” Unfortunately, over 70 years, humanity was unable to find, define and practically use “*substantially new thinking*” for its survival.

Einstein admitted the possibility of “*a world government*” only based on such “*substantially new thinking*” but not on the basis of traditional, torn, partial and militaristic thinking that deprives humanity of survival, unity and solidarity. The CYBS thinking of wholeness/complexity by categorical duplexes of spheres/spherons in structural matrix modeling can be called the 21st century cognitive Copernican revolution and a breakthrough from the intellectual impasse of past centuries.

14. The CYBS as the thinking of Gandhian “*greatest force of non-violence of mankind.*” The CYBS theory continues and develops at a new scientific level the greatest discovery and practice of Mahatma Gandhi’s non-violence through the use of his “*Newtonian law of the greatest force of mankind non-violence*” in his varnas/spherons. Gandhi, analyzing

“the whole gamut of man's activities ... [as] an indivisible whole”, wrote that it represents the indivisible unity of four **equally** necessary and sufficient spheres of society: “social, economic, political and purely religious”. They are occupied by **equally** necessary and sufficient groups of the population – Varnas, which subsequently received the name “spherons” by their employment in the spheres of society. “All [four] varnas [spherons] are equal, for the community depends no less on one than on another,” therefore they are equally necessary and sufficient together, determining the systems wholeness of every society.

“Varna is not a human invention, but an immutable law of nature—the statement of [genetic] tendency **that is ever present and at work like Newton's law of gravitation**. Just as the law of gravitation existed even before it was discovered, so did the law of varna... Varna, thus conceived, is no manmade institution but the law of life universally **governing the human family**. Fulfillment of the law would make life livable, would spread peace and content, end all clashes and conflicts, [and] put an end to starvation and pauperization... The idea of superiority or inferiority is wholly repugnant to it [varna]. Though **the law of varna is a special discovery of some Hindu seer, it has universal application**... Varna has **nothing to do with caste**. Down with the monster of caste that masquerades in the guise of varna... That is how I look at the law of varna. The world may ignore it today **but it will have to accept it in the time to come**. It ordains that everyone shall fulfill the law of one's being... Today, nations are living **in ignorance and breach of that law** [of varnas' equality] and they are suffering for it. The so-called civilized nations have by no means reached a state [of varnas development], which they can at all regard with equanimity... Without the abolition of the caste hierarchy, **there can be no peace in society and the world** ... When we revive universal human equality [of varnas/spherons]... When that day comes we shall have peace on earth and goodwill to men.” (Gandhi, 140-183).

14.1. The CYBS: Synergy of the Holistic Potentials of Gandhi, Wiener, Einstein, Maturana, Vernadsky and Kelso Based on Spherons. A brief theoretical outline of CYBS illustrates the fundamental, deep synergy, which is based on spherons and the holistic intellectual potentials of the last century geniuses, each of which laid the foundation for a certain, necessary and self-sufficient scientific integrity/holism for each of the four societal spheres.

Gandhi is the foundation of the first definition of the societal integrity/wholeness of non-violence for people/humanity.

Wiener is credited with the first definition of universal governing circular integrity/wholeness, including the governance/organization of a human society.

Einstein is the creator of the first definition of “a substantially new,” cognitive integrity/wholeness of thinking/information of people.

Maturana gives the first fundamental definition of autopoiesis (self-production), common to the entire biosphere, including society, where it acts as a conscious social production, i.e. societal autopoiesis.

Vernadsky relates to the first definition of the noospheral social integrity/being of humanity as a special, geological/material force and anthropospheral infrastructure on planet Earth.

Kelso gives the first definition of the universal holism of the “binary economy”, which complements the societal equality of Gandhi's spherons with “**equality of economic opportunities through ownership of capital**” (Kelso, 1968), which he implemented in the “**Employee Share Ownership Plan (ESOP)**” with direct and reverse ownership. The economic holism of Kelso/Kurland ensures the prevention and peaceful harmonious resolution of all economic conflicts, opening the “**Just Third Way**” of socio-economic development and converging with the Gandhian economy of “*love, equality, justice and non-violence*” of the spherons.

CYBS, on the basis of statistically and empirically proven spherons, the intuition of which is present in all the named geniuses of the last century, in the potential of each, synergistically integrates/synthesizes all the fundamental potentials of the integrity of the last

century. On their synergy, CYBS forms the science of a fundamentally new, holistic, integral, meta-, trans- and inter-disciplinary class of the XXI century: MegaScience (above). They are synergized only on the basis of spherons and only within the framework of Cyberspheronics as the highest level of organizational/governing cybernetics. CYBS provides them with synergistic, cognitive/praxiological integration/holism in MegaScience pragmatics (below). CYBS stands on the shoulders of these intellectual giants, ensuring the highest scientific fundamentality and integrity of its MegaScience, constructing and constituting it on their fundamentality, ensuring the non-violent achievement of all the goals of global peace and the eradication of all wars/militarism.

15. The CYBS Social Need. Its acuteness is set, on the one hand, by the high level of globalization of all spheres of world social production, which determines the decisive role of its integrity and global governance of it; and, on the other hand, by the systemic impotence of traditional partial social science, torn into hundreds of industry disciplines, to solve global integrity problems. This systemic weakness is demonstrated by the entire crisis situation associated with the COVID-19 pandemic at all levels: global, regional - the destruction/crisis of the EU solidarity, national - the crisis of separate countries, especially the USA, etc.

The CYBS offers a constructive alternative to systemic national impotence by its systemic “*greatest force of non-violence*” of humanity spherons (Gandhi), self-organized in their spherical structures of global governance, the first project of which for the UN was created in the GHA in 2017 (Semashko). The priority development of this alternative at the international level fully meets the constantly exacerbating social needs of humanity inherent in CYBS, which today does not have any other scientific competitive alternatives.

CYBS creates and provides in the XXI century “*cybernetic consciousness as a new noospheric phenomenon of the global information space*” (Tonkonogov, 2018).

16. The CYBS Dual, Peaceful/Military Use. In the transition period, until the completion of complete and general disarmament, there remains a dangerous possibility of militaristic use of the CYBS by one or another country or group of countries in order to achieve world domination by non-violent means. Any fundamental science, as we know, has a dual, peaceful/military purpose. CYBS is no exception from this danger.

17. International Monitoring of the CYBS MegaScience Development/Use. There can be two effective and compatible/complementary ways to control the CYBS development/use and, thus, preventing its militaristic use in the “*national egoistic interests*” of the most powerful countries or their blocks, as was the case, for example, with atomic energy in 1945 and subsequent years.

17.1. The creation of a single “*Global Academy of CYBS MegaScience*” (GACM) with regional and national branches under the auspices of the UN/UNESCO or the International Bank and the IMF, capable to finance the **CYBS MegaScience** project and exercising international control over it. The GACM will be an excellent example of international scientific and humanitarian cooperation.

17.2. The establishment within the framework of world civil society of the “*International Association of Cyberspheronics*” (IAC), uniting, on the one hand, international associations of scientists, primarily in cybernetics, such as the *American Society for Cybernetics* (ASC, 1964), *World Organization for Systems and Cybernetics* (WOSC, 1969), *ISA Sociocybernetics* (RC51, 1998), *The International Academy for Systems and Cybernetic Sciences* (IASCYS, 2016), and others such as that; and, on the other, the leading peacemaking organizations ICAN, NAPF, IPRA, IPPNW, UN2020 and the like. They are able to effectively continue the initial international development of CYBS, which was carried out in the GHA for 15 years, and better and faster than others to assess the scientific and humanitarian value of CYBS, because they are aimed not at the military, but at the peaceful development of cybernetic science and humanity. The wider CYBS will be involved in international scientific and public control, the less will be the chances of its militaristic and destructive use.

18. The CYBS Projects National Experimental Verification. The international bodies of GACM and IAC will ensure wide international verification of each CYBS project in the specific conditions of separate countries and regions as well as in the respective national universities and academies of sciences. This will facilitate integration of the CYBS projects into separate countries and will raise the level of each national science to the highest level of **global Cyberspheronics MegaScience**. To this goal, these bodies create in different countries a network of the CYBS *International Research Centers/Laboratories* (IRCLs), which will provide scientific and social experimental testing of CYBS projects, especially those previously created by the GHA with their necessary modernization.

19. The CYBS Manifesto: Humanity True Self-knowledge Beginning. The CYBS Manifesto is a manifesto of the scientific worldview/consciousness of the humanity spherons, i.e. humanity as a whole. Humanity did not know such self-awareness yet. **Only in its cybernetic form did human consciousness find its adequate, holistic expression.** This became possible only at the beginning of the XXI century; it did not work out before. Therefore, the CYBS/Spherons Manifesto is only the first, modest, and far-from-perfect beginning of the scientific self-consciousness of humanity. It will inevitably expand, correct, deepen and develop in all directions throughout the subsequent evolution/history of human/humanity, as long as it exists. The human self-knowledge, whose priority was bequeathed by Socrates more than 2000 years ago, in the Cyberspheronics true fullness and depth of the spherical societal genetics of its spherons, begins in the XXI century, more than four thousand years after it.

20. The CYBS Truth Three Simple Conditions/Steps. For more than 40 years of CYBS's difficult development, CYBS has accumulated vast experience in verification and individual conviction in its truth, which is integrated in three simple actions/steps available to every literate person, especially to every open-minded, honest and true scientist.

First step. Carefully read the integral and integral/crowning book of CYBS *Gandhica* (2019), created within the GHA by 82 coauthors from 25 countries based on numerous scientific researches and publications over the past 40 years. Recall that the proposed CYBS Manifesto is nothing more than the multidimensional focus of *Gandhica* and its quintessence.

Second step. Write a review of this book with an assessment of its scientific, methodological, social and political significance for humanity and the development of its knowledge, which becomes most vivid in comparison with the traditional paradigms of classical and post-non-classical science. This review, which is publicly available, will be a measure of the intelligence, depth and quality of the CYBS and will increase the understanding of each reviewer.

Third step. Complete a Statistical Scientific Research of Spherons (SSRS) of any city, institution, region, country according to the example of their statistical studies of 76 countries in *Gandhica* and the choice of available statistics for any period of time, for example, for the past year: 2019, 2018, 2017, etc. Only through an individual, independent SSRS is intellectual possession of the societal substance/reality of sociogenetic cybernetic spherons possible.

Over the decades of SSRS in the GHA and before, CYBS's methodology/technique was found and tested and simplified. It is presented in the book *Gandhica*, in Chapter 1, in three small paragraphs: 1.4.2., 1.4.3., and 1.4.4., on 5 pages: 32-37 (https://peacefromharmony.org/?cat=en_c&key=848). Any SSRS using this technique, resulting in 8 spherical indices per half page in the elementary statistical table, will require, as experience has shown, **no more than 4 hours from its executor**. Moreover, half of this time will take mastery of the technique and search for statistics on the Internet. You can compare and add your table to the tables of spherons of other countries and cities in *Gandhica*. Then these tables can be collected and published in a special book, "*The CYBS Statistics*," which can be produced annually both at the UN global level and at the national level. These statistics will demonstrate the dynamics of global and national spherons as the primary empirical basis for all other cybernetic studies. Similar SSRS will be massively accessible, starting with 5th grade students, when its methodology becomes a smartphones application (see below) and will ensure universal

cyber literacy in CYBS in the XXI century. The professional cyberneticians can and should start/launch this necessary and inevitable literacy. Without knowledge of spherons through SSRS, there can be no Cyberspheronics as MegaScience; there can be no “*substantially new manner of thinking*”; there can be no mastery of the “*greatest force of non-violence*”; there cannot be implementation of CYBS in any practical project.

VI. Cyberspheronics Pragmatics. The Best Global Security is Global Peace

1. The CYBS Pragmatics/Praxeology and its Economic Efficiency. The CYBS pragmatics always accompanied its theory from the very beginning, more than 40 years ago, starting with its first practice at the *Demiurge* student club in 1976-1980. The CYBS highest practical goal is to ensure humanity’s survival and save the noosphere from the global ecocide/genocide in the XXI century. We can name at least six fundamental innovations of CYBS, which will ensure the achievement of this pragmatic goal based on its spherical statistics and technology.

1.1. The development of spherical statistics and CYBS technology will require the creation of new research centers and laboratories in each country with millions of new, highly intellectual jobs and the corresponding innovative information infrastructure. National and international statistical agencies are the most prosperous and interested institutions in the development of spherical statistics.

1.2. CYBS and its digital technologies will ensure the creation of a spherical Internet, which will put the traditional Internet under control, overcoming its spontaneity, fragmentation, destructiveness and other well-known limitations and vices thereof.

1.3. CYBS and its digital technologies will provide a development trend for a new, spherical artificial intelligence (SAI), which integrates the achievements of traditional AI and provides control over its further development to exclude any threats to humanity’s survival.

1.4. CYBS and its digital technologies will provide a theoretical and information platform for a new, non-violent democracy that excludes war, violence, militarism and the arms race. This democracy will be able to establish itself, with appropriate mass enlightenment/education and strategic global governance training, over the next 50 years or by the end of the XXI century, as the GHA studies have shown (GPS, 2016; Gandhica, 2019; etc.).

1.5. CYBS and its digital technologies show the only cardinal way to solve the global environmental problem: overcoming global warming and establishing a harmonious and sustainable spherical balance between nature and humanity through control and global governance of interactions between their spheres.

1.6. CYBS and its digital technologies open up the production of an almost unlimited class of applications for individual smartphones of two key varieties. A) For planning/managing the spherical resources of individual autopoiesis within the different periods of its life time space, starting, from the age of 10, with a view to the most promising and successful personal growth, and harmonious development. B) For leaders of any rank and organization of any scale for individual design, comparison and selection of the most optimal development strategies for these organizations through the harmonization of their spheres/spherons. Any similar application for an individual smartphone is a pocket-sized artificial intelligence (PAI) device of the highest level as an indispensable tool for any thinking individual who cares about the most effective development of both his own personality and the organization he or she leads. The PAI will ensure the interaction of AI and humans at all levels of a cybernetic society (Tonkonogov, 2018).

The PAI applications along with other CYBS pragmatics create a new market of CYBS digital spherical technologies, unlimited in time, demand and variety, which will endlessly pay for any starting investments in them.

These and many other CYBS innovations, private and derivative from them, provide a breakthrough for business and global governance in this direction to a qualitatively different level of business/pragmatic, social and economic efficiency.

2. The CYBS Projects Total Number. For more than 40 years of CYBS, there have been about 300 industry and regional projects in all spheres and at different levels. These projects started since the spherons structure was first tested in the student club of harmonious development "*Demiurge*" in 1976 – 1980 (Semashko, 2017). The projects were first politically tested in the "*Spherical Democracy Faction*" in the St. Petersburg first democratic Parliament, "*Petrosoviet*", in 1992 – 1993 (Semashko, 2010). The lists of similar projects are published in many GHA books listed in the bibliography. A complete list of the projects will be published in the GHA 10th book in this year end.

3. The Most Ambitious and Fundamental CYBS Project: "The UN Harmony Spherical Model". This project was created by the GHA in 2017 to participate in the projects contest of the Swedish "*Global Governance Foundation*". "*The UN Harmony Spherons Structure*" (Semashko, 2017), presented below, summarizes this project. This model assumes that each United Nations state-member has 8 national emissaries in the UN (in gender balance by 2 representatives from each of the four national spheres), which would amount to 1,600 members of its General Assembly for 200 UN state-members. It could democratically fulfill the functions of "a world government" (Einstein), providing global peace from spherons harmony at all levels from municipal to global.

The UN Harmony Spherons Structure (GHA, 2017)



https://www.peacefromharmony.org/?cat=en_c&key=769

The type of this model creates at all governing levels and in all structural units of both a sectoral/branch and regional nature the spherical structures. Examples of many of them are presented in the list of CYBS projects.

4. Holistic MegaScience: Full Social Responsibility. Through holistic Cyberspheronics/Megascience, for the first time in history, humanity will receive such scientific knowledge that it will be able to take and bear full scientific social responsibility for the quality of all autopoietic structures and processes of humankind/noosphere, ensuring its survival and prosperity for all people. In contrast to the rupture of traditional scientific knowledge/thinking in hundreds of partial "subdisciplines" devoid of a unifying cybernetic platform of spheres/spherons, whose social responsibility was practically zero for 75 years, when the threat of a global nuclear ecocide/genocide arose, **CYBS for the first time opens such an opportunity of world/universal responsibility for all of humanity.** This is the natural way for

the evolution of social responsibility from its current partial/fragmentary forms to its fullness and integrity with CYBS. The historical path of evolution of social responsibility is considered in detail in the writings of Matjaž Mulej (2016, 2019 and others) and his Institute for Social Responsibility. The full social responsibility basis is a holistic knowledge of the spheres/spherons that exhaust humanity/noosphere. Without their knowledge, all liability is flawed and limited.

5. Holistic Cybernetic Megascience: Global Democratic Federation and World Government Foundation. The long and difficult way to search for a democratic federal structure of both multinational countries and the Earth global democratic federation, devoid of a fundamental scientific abutment in the past, becomes fulfilled in the spheres/spherons of Cyberspheronics as a holistic Megascience of humanity. The conscious organization of the social life and political power of each people/nation and humanity as a whole on the basis of spheres/spherons of the appropriate scale, level and cultural-historical diversity, disclosed in the CYBS, creates a fundamentally substantiated single platform for the Earth global democratic federation at all levels from municipal to world, as confirmed by holistic cybernetic science. At the same time, the CYBS becomes a fundamental scientific pillar of the world government (Einstein), the world parliament and the Earth's Constitution. CYBS also becomes a fundamentally new peacemaking tool than can save humanity of all sorts of wars, according to the UN and its corresponding Security Council and its Charter (Kotila, 2016 and others; Martin , 2018, etc.). The spherons equality is the social foundation/law of scientific federalism and its Constitution, without which they (democracy, federalism and their constitutions) remain shaky and unstable, from within which fascist and other totalitarian regimes easily arise, as history has shown many times.

6. Holistic Cybernetic MegaScience as a Common Scientific Platform for the Integration of Various Environmental Projects. There are many disparate interdisciplinary environmental projects that receive in CYBS the necessary scientific substantiation and integration with other projects. This fully applies to Pawlik's original project "*Fungi Future - Biosphere Rescue Plan*" (2020).

7. Spherons Manifesto as the Manifesto of the Norm Replacing the Humanity Pathologies. Humanity/society, as a social organism of the highest complexity, has its own norm and pathologies. Their knowledge requires fundamental science, to which humanity has not yet matured and is only entering its first stage creating it in the MegaScience of Cyberspheronics. CYBS, penetrating into the spherons' genetic level of humanity, offers fundamental scientific knowledge of the social norms of love, harmony, peace and non-violence. Only this genetic societal norm provides humanity with continuous reproduction, uninterrupted life, survival and prosperity. The spherons in love, harmony, non-violence and peace constitute the only internal source of their being, with all its infinite historical, cultural and civilizational diversity. Spherons are the source of human health and beneficial norms.

The source of social pathologies/diseases of humankind, whether mild or severe, are deviations from the norm. These deviations have occurred at various historical stages among various, historical transient parts/partons of humanity: nations, classes, groups, parties, elites, states, etc. They give rise to certain social pathologies that often reach extreme ugliness. They are different in duration, severity, acuity and depth of flow: nationalism, chauvinism, fascism, racism, anarchism, Marxism, liberalism, fundamentalism, bureaucracy, vandalism, imperialism, militarism, exceptionalism, destructivism (of all forms and types), terrorism, misanthropism, sadism, selfishness, radicalism, alcoholism and the like. The scientific atlas/encyclopedia of social pathologies has not yet been compiled due to the lack of science, but CYBS creates the basis for it, both as a whole for humanity and in its spheres/spherons, as well as in different historical eras. This is a matter for the future.

It is important to emphasize that different forces can use knowledge of social pathological anatomy for different purposes: to cure any social organism, to kill it as soon as possible, or to exacerbate pathology. Humanity has no fewer pathologies than the human organism, but only

CYBS approaches resolution of those pathologies through scientific, systemic and holistic knowledge.

8. Summary. The CYBS Manifesto: The Manifesto of Humanity Spherons Third Way, Outside of Capitalism/Communism. Cyberspheronics (CYBS) finds in the equal, structurally eternal and universal spheres/spherons of humanity its deepest societal genetic nature of its wholeness. Cyberspheronics provides humanity and the planet with survival in the framework of a harmoniously organized spherical social autopoiesis, subject to the laws of sustainable ecology. Cyberspheronics frees humanity from the global nuclear ecocide/genocide. We discuss this issue in detail and with the necessary justification in *Gandhica* (Conclusion).

Therefore, the CYBS Manifesto is the Manifesto of humanity's survival, its holistic harmonious worldview, alternative to all partial, monistic and destructive ideologies of the past. This is Manifesto of the genetically equal spherons and their conscious/scientific, "*substantially new*" **Third Way** to the era of peace, love, harmony and non-violence. The science of self-knowledge of humanity is finally reached the values of this era, following in the footsteps of Gandhi.

The CYBS Manifesto is an alternative to all past Manifestos of violence, including communism and liberalisms (Oxford, 1997). In place of various architectures/dictatorships of the deadly parts of humanity of different colors (white, black, red, green, rainbow, etc.), the CYBS Manifesto creates a fundamental scientific architecture/democracy of non-violence by equally necessary and sufficient spheres/spherons of humanity/noosphere as a whole. The CYBS guarantees humanity equality, justice, peace, love, brotherhood, freedom, non-violence and happiness of all peoples in their harmony while also retaining all constructive achievements of the past.

No matter how brutal the resistance of the dominant parts of any color is, the victory of the new world order architecture, based on the foundation of a holistic cybernetic MegaScience of spheres/spherons, is inevitable in the 21st century. Mahatma Gandhi first predicted non-violent victory almost a century ago. Therefore, the CYBS Manifesto is the Gandhian Manifesto of the Future and its New Generations. It is the spherons' Manifesto of love, harmony, peace and non-violence for an evolving mature reasonable humanity.

05-08-20

Beatrice Fihn,

ICAN Executive Director, Sweden,

ICAN is Nobel Peace Laureate 2017,

https://peacefromharmony.org/?cat=en_c&key=943

Email: admin@icanw.org

Leo Semashko, PhD,**

Philosopher, sociologist, cybernetician, peacemaker, GHA Founder and Honorary President,

The ISA RC51 Sociocybernetics Honourary Lifetime Member,

Initiator and Editor-in-Chief of the "*Peace/Cyberspheronics Manifesto*",

Blog: https://peacefromharmony.org/?cat=en_c&key=253

Email: leo.semashko@gmail.com

Skype: leo.semashko

Phone home: 7-812-597-6571

** The cybernetic ideas presented in this *Manifesto* and *Gandhica* grew up in close cooperation and friendship with Bernard Scott, a well-known British cybernetics for the past 20 years, including 15 years in the GHA (Global Harmony Association: International peacemaking organization of scholars-humanities, established in 2005: <https://peacefromharmony.org>). His fundamental ideas are important intellectual contribution to this Manifesto. The main milestones of our cooperation over 20 years are presented on the GHA website. I cannot forget their and am happy to express to him my highest appreciation and gratitude. Leo Semashko. May 31, 2020.

Bibliography

- Almond G. (1990) *A Discipline Divided: Schools and Sects in Political Science*. 1990. SAGE Publications.
- Almond G., Verba S. (1963) *The Civic Culture: Political Attitudes and Democracy in Five Nations*. Princeton University Press.
- Anonymous. "Cybernetics is a false science." 2019 (In Russian) To whom? For what? https://peacefromharmony.org/?cat=ru_c&key=842
- Ashby, W. *An Introduction to Cybernetics*. – London: Chapman and Hall, 1956.
- Ashford R. (1996) Louis Kelso's Binary Economy. *The Journal of Socio-Economics*, Vol. 25, No. 1, 1996.
- Avery J. (2017) Nuclear Weapons: An Absolute Evil: http://peacefromharmony.org/?cat=en_c&key=800
- Avery J. (2018) A World Federation: <http://eacpe.org/app/wp-content/uploads/2018/11/A-World-Federation-by-John-Scales-Avery.pdf>
- Avery J., Semashko L. and others (2017) Thermodynamics and Negentropy of Spherical Classes Societal Harmony: http://peacefromharmony.org/?cat=en_c&key=756.
- Bateson, G. *Steps to an Ecology of Mind*, Paladin, New York, NY, 1972.
- Berndt, H.; Scott, B.; Semashko, L. Tetrasociology and sociocybernetics: towards a comparison of the key concepts, 2003. – Pp. 222–232. – https://peacefromharmony.org/docs/2-2_eng.pdf.
- Brennan J. *Against Democracy*, 2016. press.princeton.edu.
- Chappell P. (2012) *PEACEFUL REVOLUTION: How We Can Create the Future Needed for Humanity's Survival*. Easton Studio Press: <https://paulkchappell.com/peaceful-revolution/>
- Covey, Stephen R. (2011). *The 3rd Alternative*. New York: Free Press
- Durkheim, E. *The Division of Labour in Society*, 1996.
- Ecimovic, T. SPHERONS' Argumentation: Detailed Review, 2017. – https://peacefromharmony.org/?cat=en_c&key=747.
- Ecimovic, T.; Avery, J.; Semashko, L. *THE CLIMATE CHANGE SYSTEM 2017*. Ed. 2017. – https://peacefromharmony.org/docs/ECIMOVIC_CLIMATE%20CHANGE_18-04-17_Final.pdf
- Einstein, A. on Peace and Gandhi, in Richard B. Gregg, *Profiles in Gandhi*. – P. 100.
- Einstein, A. Quotes, 1955. – <https://www.brainyquote.com/quotes/quotes/a/alberteins104567.html>.
- Eisler R. (1994) *The Chalice and The Blade*. Harper Collins San Francisco: https://peacefromharmony.org/?cat=en_c&key=932
- Fedotova V. G. "European Third Way" and Its Symbolic Significance for Russia and Other Countries. *Sociological Review* Volume 2. No 1. 2002 (In Russian): https://sociologica.hse.ru/data/2011/03/30/1211856451/2_1_1.pdf
- Fihn B., Thurlow S. (2017) International Campaign to Abolish Nuclear Weapons (ICAN). – Nobel Lecture: <https://www.nobelprize.org/prizes/peace/2017/ican/26041-international-campaign-to-abolish-nuclear-weapons-ican-nobel-lecture-2017/>
- Foerster, H. *Understanding understanding*. New York, NY: Springer Verlag, 2003.
- Foerster, H.; Broecker, M. *Teil der Welt. Fraktale einer Ethik. Ein Drama in drei Akten*, Heidelberg: Carl-Auer Verlag, 2002.
- Foerster, H.; Freund, S. *Heinz von Foerster. Cyber-Ethics: A Portrait*, 1992.
- Galtung, J. *A Theory of Conflict: Overcoming Direct Violence*. TRANSCEND University Press, 2010.
- Galtung, J. *Cultural Violence*. *Journal of Peace Research*, 1990. – Vol. 27, 3.
- Gandhi M. (1946) *My Life Is My Message*. H, 1-6, p.172: www.mkgandhi.org/momgandhi/chap94.htm
- Gandhi M. (1982) *On Nuclear Arms*: <https://www.mkgandhi.org/articles/NuclearArms.htm>
- Gandhi M. (1998) *Mine & Metal Workers, Gandhi Jayanti 1998*: https://www.mkgandhi.org/articles/constr_prog.htm
- Gandhi M. (2014) *My life is my message*. Compiled by: Krishna Kripalani. Printed Navajivan, Ahmedabad: <https://www.mkgandhi.org/ebks/ownwords.pdf>
- Gandhi, M. *My Religion*, 1955: <http://gandhisevagramashram.org/pdf-books/my-religion.pdf>
- Giddens A. *The Third Way: the Renewal of Social Democracy*. Cambridge: PolityPress, 1998.
- Greaney M., Kurland N. (2016) Pope Francis and the Just Third Way: Global Peace from Harmony: https://peacefromharmony.org/?cat=en_c&key=414
- Gunther, G. (1972). *Cognition and Volition: A Contribution to the Theory of Subjectivity*. In *Collected Works of the Biological Computer Laboratory* (University of Illinois, Urbana, Illinois). Peoria, IL: Illinois Blueprint Corporation: http://www.vordenker.de/ggphilosophy/c_and_v.pdf
- Heylighen F. & Lenartowicz M. (2020) *Cybernetics*. (Preprint, to be published in: Ritzer G. & Rojek C. (eds.) (2021) *Wiley Blackwell Encyclopedia of Sociology* (2nd. edition, Wiley-Blackwell Science publishers)
- Heylighen F. and Joslyn C. *Cybernetics and Second-Order Cybernetics*. In: R.A. Meyers (ed.), *Encyclopedia of Physical Science & Technology* (3rd ed.), Academic Press, New York, 2001: <http://pespmc1.vub.ac.be/Papers/Cybernetics-EPST.pdf>
- https://peacefromharmony.org/?cat=en_c&key=946
- Kelso L. and Adler M. (1958) *The Capitalist Manifesto*. Random House, New York;
- Kelso L. and Kelso P. (1968) *Equality of Economic Opportunity Through Capital Ownership...* Doubleday & Co., New York;
- Kotila R. (2016) *World Federalists Seek Leadership from the European Union for a New UN*: https://peacefromharmony.org/?cat=en_c&key=680
- Krasnov V. (2019) *Mahatma Gandhi and Aleksandr Solzhenitsyn, The Two Giants Who Blessed the 20th Century*. Will Vladimir Putin, Other World Leaders Listen?: https://www.peacefromharmony.org/?cat=en_c&key=884
- Kurland N. (1982) *The Capital Homestead Act*: www.cesj.org
- Kurland N., Brohawn D., Greaney M. (2014) *The Just Third Way. How We Can Create Green Growth, Widespread Prosperity and Global Peace*: Center for Economic and Social Justice; www.cesj.org
- Kurland N., Michael D. Greaney M. and others (2012) *CESJ. OUR CORE VALUES. OUR CODE OF ETHICS*: <http://www.cesj.org>
- Lepskiy V.E. *Philosophical-Methodological Basis for the Formation of Third-Order Cybernetics*. *Russian Journal of Philosophical Sciences*. 2018;(10):7-36. (In Russ.) <https://www.phisci.info/jour/article/view/2359/2612>
- Lepskiy V.E., Zadorozhnyuk I.E., & Pirozhkova S.V. (2018) *Search Vector – Third-Order Cybernetics (Review of the International Interdisciplinary Scientific and Practical Symposium)*. *Voprosy Filosofii*. 2018. No. 6, pp. 208–211 (in Russian): http://vphil.ru/index.php?option=com_content&task=view&id=2002&Itemid=52
- Lown B., Chazov Y. (1985) *IPPNW Nobel Peace Prize Lecture*: https://www.nobelprize.org/nobel_prizes/peace/laureates/1985/physicians-facts.html ; <https://ru.citaty.net/tsitaty/1924964-bernard-lown-we-physicians-protest-the-outrage-of-holding-the-e/>
- Luhmann, N. *Introduction to Systems Theory*. –M.: Publishing House "Logos", 2007.
- Maguire M., Avery J., Semashko L. (2018) *US-Russia Summit. The Great Peace Charter XXI*: <https://www.globalresearch.ca/us-russia-summit-a-manifesto-and-roadmap-of-global-peacebuilding-in-the-21st-century/5647028>
- Mandelbrot, B. *The Fractal Geometry of Nature*. San Francisco: W.H. Freeman and Company, 1982.
- Martin, G. (2018). *Global Democracy and Human Self-Transcendence: The Power of the Future for Planetary Transformation*. Cambridge, UK: Cambridge Scholars Publishers.
- Maturana, H. *Neurophysiology of cognition*, in Garvin, P. (Ed.), *Cognition: A Multiple View*. – Spartan Books, New York, NY, 1970. – Pp. 3–23.

- Maturana, H., Varela, F. Autopoiesis and Cognition, D. Reidel, Dordrecht, 1980.
- Maturana, H., Varela, F. Autopoiesis: the organization of the living, 1973// Maturana H., Varela F. Autopoiesis and Cognition.– Boston, 1980. – P. 63–134.
- McCulloch, W. A heterarchy of values determined by the topology of nervous nets, 1945. – Pp. 89–93.
- McCulloch, W. Embodiments of Mind. – Cambridge, Mass.: MIT Press, 1965.
- McMurtry, J. U.S. Holds the World Record of Killings of Innocent Civilians, 2013. – <http://www.globalresearch.ca/u-s-holds-the-world-record-of-killings-innocent-civilians/5393789>.
- Mecklin J. (2020) Closer than ever: It is 100 seconds to midnight. 2020 Doomsday Clock Statement: https://peacefromharmony.org/?cat=en_c&key=924
- Mulej M. (2016) *Social responsibility as a Precondition for Peace and Development Instead of the Current Global Socio-economic Crisis*: https://peacefromharmony.org/?cat=en_c&key=473
- Mulej M. (2019) *Gandhian Democracy. Full Social and Peace Responsibility of Society: Innovation, Utopia and Systemic Behavior*: https://peacefromharmony.org/?cat=en_c&key=473
- Neumann, J. Theory of Games and Economic Behavior. – New Jersey: Princeton University Press, 2004.
- Oxford Manifesto 1997. The Liberal Agenda for the 21st Century: The Liberal Manifesto, 1997, Oxford, UK: https://web.archive.org/web/20110207012341/http://www.liberal-international.org/editorial.asp?ia_id=537
- Paetau, M. Niklas Luhmann and Cybernetics. Journal of Sociocybernetics, 2013. – Vol 11, No ½. – <https://papiro.unizar.es/ojs/index.php/rc51-jos/article/view/790>.
- Parsons, T. “The Present Status of ‘Structural-Functional’ Theory in Sociology”, Social Systems and The Evolution of Action Theory, New York: The Free Press, 1975.
- Parsons, T. American Society: A Theory of Societal Community. – Paradigm Publishers, 2007.
- Parsons, T. The Present Status of ‘Structural-Functional’ Theory in Sociology. Social systems and the evolution of action theory, New York: Free Press, 1977. – P. 100–117.
- Pask, G. A cybernetic model for some types of learning and mentation. In Cybernetic Problems in Bionics, Oestreicher, H.C. and Moore, D.R., (Eds.), Gordon and Breach, 1968. – Pp. 531–585.
- Pask, G. Conversation, Cognition and Learning. – Elsevier, Amsterdam and NY, 1975.
- Pawlik L. (2020) Fungi Future - Biosphere Rescue Plan: https://peacefromharmony.org/?cat=en_c&key=887
- Pawlik, L. Hack or Die: How Humanity Steers Into Its Post-Digital Future. World Futures, 2019. –p. 58–68. –: http://www.academia.edu/Documents/in/Heinz_von_Foerster.
- Piaget, J. Psychology and Epistemology. – Penguin, Harmondsworth, Middx, 1977.
- Pias, C. Cybernetics – Kybernetik (The Macy-Conferences 1946–1953). 2vols. Zurich & Berlin: Diaphanes, 2004.
- Poincare, H. The Foundation of Science. The Science Press. New York And Garrison, N.Y., 2013. – <https://archive.org/stream/foundationsscie>.
- Poincare, H. The Foundations of Science, 1913. – <https://archive.org/stream/foundationsscie01poingoo#page/n224/mode/2up/search/201+page>.
- Poincare, H. The Value of Science. New York: Dover, 1958.
- Rush B. (1984) A Plan of a Peace Office for the United States. Massachusetts Review
- Scott B. Guest Column: In Defence of Pure Cybernetics. Cybernetics and Human Knowing. Vol. 26 (2019), no. 4, pp. 99-110: https://peacefromharmony.org/?cat=en_c&key=946
- Scott, B. Cybernetic foundations for Psychology. Constructivist Foundations, 2016. – 11(3) – pp. 509–517.
- Scott, B. Education for cybernetic enlightenment. Cybernetics and Human Knowing, 2011. – 21(1-2) – PP. 199–205.
- Scott, B. Explorations in Second-Order Cybernetics: Reflections on Cybernetics, Psychology and Education. – Edition echoraum, Vienna, 2011.
- Scott, B. Human systems, communication and educational psychology, educ. Psychol. in Practice, 1987. – 3, 2 – pp. 4–15.
- Scott, B. Morality and the cybernetics of moral development. Int. Cybernetics Newsletter, 1983. – 26 – pp. 520–530. Reprinted as chapter 5 in Scott, 2011.
- Scott, B. on Becoming a Cybernetician: Highlights and Milestones. World Futures, 2019. – 0: 1–12. – <https://www.tandfonline.com/eprint/bZGfNBUIVcCTsW2HSyv3/full?target=10.1080/02604027.2019.1591082>
- Scott, B. Second order cybernetics: an historical introduction, Kybernetes, 2004. – 33, 9/10 – pp. 1365–1378.
- Scott, B. Second-order cybernetics as cognitive methodology, Systems Research, 1996. – 13, 3 – pp. 393–406.
- Scott, B. Sociocybernetic Reflections on the Human Condition. ISA Forum Vienna, 2016 – https://peacefromharmony.org/?cat=en_c&key=742.
- Scott, B. Sociocybernetic understandings of consciousness, 2017. – https://peacefromharmony.org/?cat=en_c&key=742.
- Scott, B. Some thought about Leo Semashko’s concept of ‘spherons’: ISA RC51 on Sociocybernetics. Newsletter 34, September 2017. – <https://sociocybernetics.files.wordpress.com/2017/09/rc51-newsletter-34.pdf> .
- Scott, B. Tetrasociology. Editor's Introduction, 2002. – https://peacefromharmony.org/?cat=en_c&key=147.
- Scott, B. The cybernetics of Gordon Pask, in Gordon Pask, Philosopher Mechanic: An Introduction to the Cybernetician’s Cybernetician, R. Glanville and K.H. Müller (eds.). – Edition echoraum, WISDOM, Vienna, 2007. – Pp. 29–52.
- Scott, B. The role of Sociocybernetics in understanding world futures, Kybernetes, 2009. – 38, 6, pp. 867–882: – https://peacefromharmony.org/?cat=en_c&key=741.
- Scott, B. Using the logic of life to reduce the complexity of life. Cybernetics and Human Knowing, 2012. –19, 3 – pp. 93–104.
- Scott, B. Working with Gordon: developing and applying Conversation Theory (1968–1978), Systems Research, 1993. – 10, 3 – pp. 167–182.
- Semashko L. (2004) Manifesto of Spherical Democracy (In Russian): https://peacefromharmony.org/?cat=ru_c&key=392
- Semashko L. (2010) “Spherical Democracy Group” in Petrosoviet 1992: https://peacefromharmony.org/?cat=en_c&key=58
- Semashko L. (2010) “Spherical Democracy Group” in St-Petersburg Parliament 1992: https://peacefromharmony.org/?cat=en_c&key=58
- Semashko L. (2017) Philosophy and Dialectics of Spherons: From “Demiurge” (1976-1980) to the UN: https://www.peacefromharmony.org/?cat=ru_c&key=305
- Semashko L. (Ed. 2020) GHA 77th Project. *The World Civil Society Security Council* (WCSSC): https://peacefromharmony.org/?cat=en_c&key=941
- Semashko L., Baimuratov U., et al. (2017) Manifesto of the Noosphere Spherons (In Russian): https://peacefromharmony.org/?cat=ru_c&key=711
- Semashko L., DeWitt M. (2004) Children’s Suffrage: Democracy for the 21st Century: https://peacefromharmony.org/?cat=en_c&key=211
- Semashko L., Siebert R. (2017) Spherons of Harmony: The Third Way of Religions Reconciliation: https://peacefromharmony.org/?cat=en_c&key=782
- Semashko L.; Авери, Дж.; Афанасьева, В.; Экимович, Т. Термодинамика и негэнтропия социетальной гармонии сферных классов: термодинамика глобального мира, 2017 – https://peacefromharmony.org/?cat=ru_c&key=728.
- Semashko, L. and 119 coauthors from 34 countries. Harmonious Civilization: 2009: https://peacefromharmony.org/?cat=en_c&key=379.

Semashko, L. and 174 coauthors from 34 countries. Global Peace Science, 2016. – <https://peacefromharmony.org/docs/global-peace-science-2016.pdf>

Semashko, L. and GHA 20 coauthors. Network Spherons: The UN of Harmony and Global Peace Replacing the UN of Disharmony, 2017 – https://peacefromharmony.org/?cat=en_c&key=769.

Semashko, L. and others. SPHERONS' Argumentation: Advantages and Disadvantages, 2017. – https://peacefromharmony.org/?cat=en_c&key=747.

Semashko, L. and the GHA 32 coauthors from 13 countries. Message to BRICS and other Peaceful States Leaders, 2015. – https://peacefromharmony.org/?cat=en_c&key=632.

Semashko, L. and the GHA 75 coauthors from 26 countries. The ABC of Harmony for World Peace, Harmonious Civilization and Tetranet Thinking, 2012. – https://peacefromharmony.org/?cat=en_c&key=478.

Semashko, L. Deep Social Structure of SPHERONS' Harmony: Copernican Revolution of Sociology in the XXI Century, 2017. – https://peacefromharmony.org/?cat=en_c&key=726 ;

Semashko, L. Human/Humanity Right to Life, Global Peace and Social Harmony. GHA Declaration 2017: https://peacefromharmony.org/?cat=en_c&key=798.

Semashko, L. Sociology for Pragmatists. Textbook for the university students. Part 1, St.-Petersburg, 1999. – 376 p. (in Russian). – <https://peacefromharmony.org/docs/sociologiya-dlya-pragmatikov.pdf>.

Semashko, L. Spherical Approach. – St-Petersburg, Notabene, 1992. – https://peacefromharmony.org/file/5162/1992-semashko-sferniy_podhod.pdf.

Semashko, L. Spherons' Sociocybernetic MegaScience, 2018. – https://peacefromharmony.org/?cat=en_c&key=810.

Semashko, L. Tetrasociology: from Sociological Imagination through Dialogue to Universal Values and Harmony, with 14 co-authors, in three languages. St.-Petersburg State Polytechnic University, 2003, 394p. http://www.peacefromharmony.org/?cat=en_c&key=149

Semashko, L. Tetrasociology: Responses to Challenges. – St.-Petersburg State Polytechnic University, 2002. – https://peacefromharmony.org/docs/2-1_eng.pdf.

Semashko, L. The ABC of Harmony as Sociocybernetics of the Third Order, 2012. – https://peacefromharmony.org/?cat=en_c&key=64.

Semashko, L. The Software Product Person (SPP) for Harmonious Development and Personal Growth. Information Technology, 2015. – https://peacefromharmony.org/?cat=en_c&key=600.

Semashko, L.; Chandra, S. Key to Global Peace Science...: Global Peace Science. Peace science: First Common Good and Human Right, Revolution of Social Sciences, 2015. – https://peacefromharmony.org/?cat=en_c&key=624.

Semashko, L.; Chandra, S.; Pereira, T. The USA Hiroshima: Nuclear Threat to Humanity. GHA Message, 2015. – https://peacefromharmony.org/?cat=en_c&key=630.

Semashko, L.; Kashina, O. Global Peace Genetics: Structural Harmony of Russia's Spherons in their Statistics for 2010, 1996 и 1991. Edition 2018. – https://peacefromharmony.org/?cat=en_c&key=836.

Semashko, L.; Semashko, A. Psychological Human Genome: Global Peace from Individual Harmony / Global Peace Science, 2015. – P. 232–234. – <https://peacefromharmony.org/docs/global-peace-science-2016.pdf> .

Siebert R. (2020) The Third Way: https://peacefromharmony.org/?cat=en_c&key=945

Spencer-Brown, G. The Laws of Form. London: Allen and Unwin, 1969.

The Third Way: Progressive Governance for the 21st Century // The White House. 25 April 1999.

The U.N. Treaty on the Prohibition of Nuclear Weapons 2017: https://www.icanw.org/the_treaty

Tonkonogov A. Cybernetic Consciousness as a Social Phenomenon of the XXI Century. Law and Right. No. 9. 2019. P. 23-27 (In Russian): <https://cyberleninka.ru/article/n/kiberneticheskoe-soznanie-kak-sotsialnyy-fenomen-xxi-veka/viewer>.

Tonkonogov A. Cybernetic Society as a Reality of the 21st Century // Law and Right. No. 9. 2018. P. 23-27 (In Russian): <https://cyberleninka.ru/article/n/kiberneticheskoe-obschestvo-kak-realnost-xxi-veka/viewer>

Umpleby, S. Heinz von Foerster and the Mansfield Amendment. Cybernetics & Human Knowing, 2003. – 10 (3–4) – pp. 161–163.

Valtsev S. Democracy. The Humanity Sunset. 2018: <https://wowavostok.livejournal.com/9651668.html>

Valtsev S. Why is democracy impossible? The Humanity Sunset. 2016: <http://rusmissia.ru/ch-iii-byt-ili-ne-byt/glava-ii-politicheskaya-sistema/2-ob-odnom-ustojchivom-mife/pochemu-demokratiya-nevozmozhna.html>

Vernadsky V. (1931) Biosphere and Noosphere: <http://www.rulit.me/books/biosfera-i-noosfera-read-412871-126.html> (and: https://www.peacefromharmony.org/?cat=ru_c&key=705)

Von Foerster, H. on self-organising systems and their environments, in Self-Organising Systems, M. C. Yovits and S. Cameron (Eds.), London: Pergamon Press, 1960. – PP. 30–50.

Von Foerster, H. Understanding Understanding: Essays on Cybernetics and Cognition, Springer-Verlag, Berlin, 2003.

Von Foerster, H., et al. (Eds), Cybernetics of Cybernetics, BCL Report 73.38, Biological Computer Laboratory, Department of Electrical Engineering, University of Illinois, Urbana, IL, 1974.

Von Foerster, H., Mead, M. and Teuber, H.L. Editors' Introduction to Cybernetics: Circular Causal and Feedback Mechanisms in Biological and Social Systems, Josiah Macy, Jr Foundation, New York, NY, 1953.

Vygotsky, L. Thought and language. – MIT Press, Cambridge MA, 1962.

Weizenbaum, J. Computer Power and Human Reason. From Judgement to Calculation. New York: W.H. Freeman and Company, 1976.

Wiener N. The human use of human beings. Cybernetics and Society. London, Eyre and Spottiswoode, 1954

Wiener, N. Cybernetics. Camb. Mass: MIT Press, 1948.

Wiki. Criticism of democracy. https://en.wikipedia.org/wiki/Criticism_of_democracy

Wittgenstein, L. Philosophical Investigations. – Basil Blackwell, Oxford, 1953.

WOSC. Philosophical-methodological basis of third-order cybernetics. 2020: <https://wosc2020.ipu.ru/>
